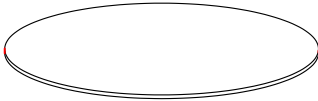
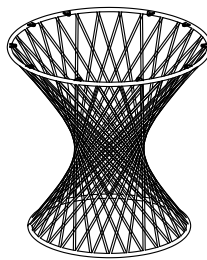

### PART LIST

 <p>A : TABLE TOP x1</p>	 <p>B : METAL LEG x1</p>	
---	---	--

### HARDWARE LIST

 <p>C : PAN HEAD SCREW M4 x 16MM x10</p>	
---	--

### STEP 1

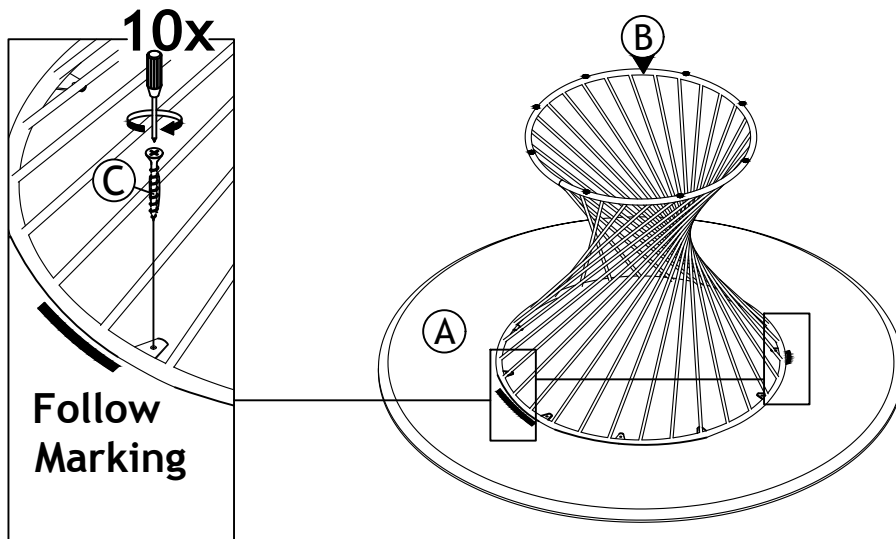

### STEP 2

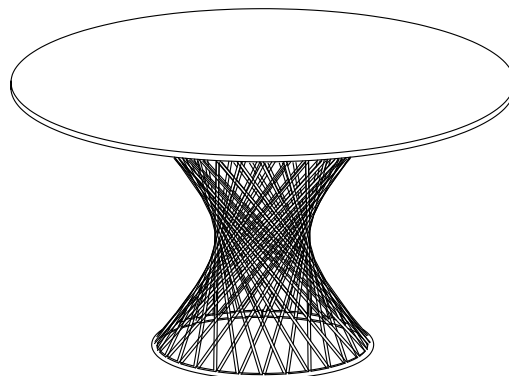

ASSEMBLY COMPLETED



# Product Assembly Instructions

## CHANNELL DINING CHAIR

### PART LIST

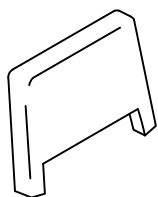

A : BACKREST x1

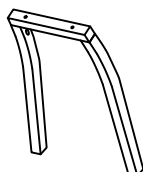

B : BACK LEG x1

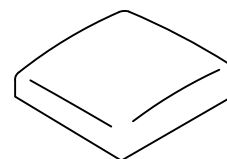

C : SEAT CUSHION x1

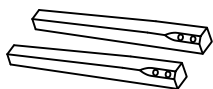

D : FRONT LEG (L &R) x2

### HARDWARE LIST



E : JCBC SCREW M6 x 45mm x12



F : SPRING WASHER 1/4" x12



G : FLAT WASHER 1/4" x8



H : M4 ALLEN KEY (BALL SHAPE) LONG x1

### STEP 1

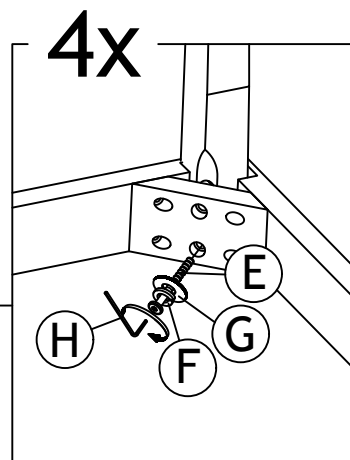
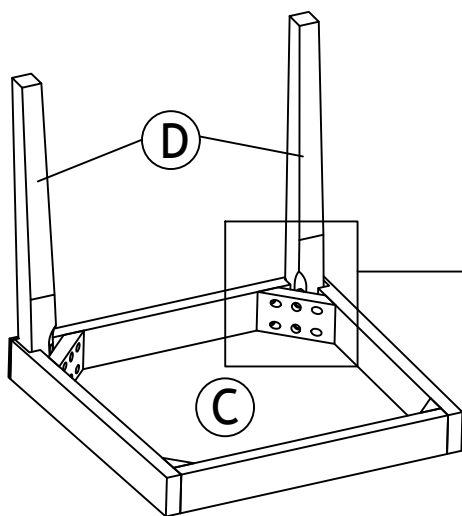

STEP 2

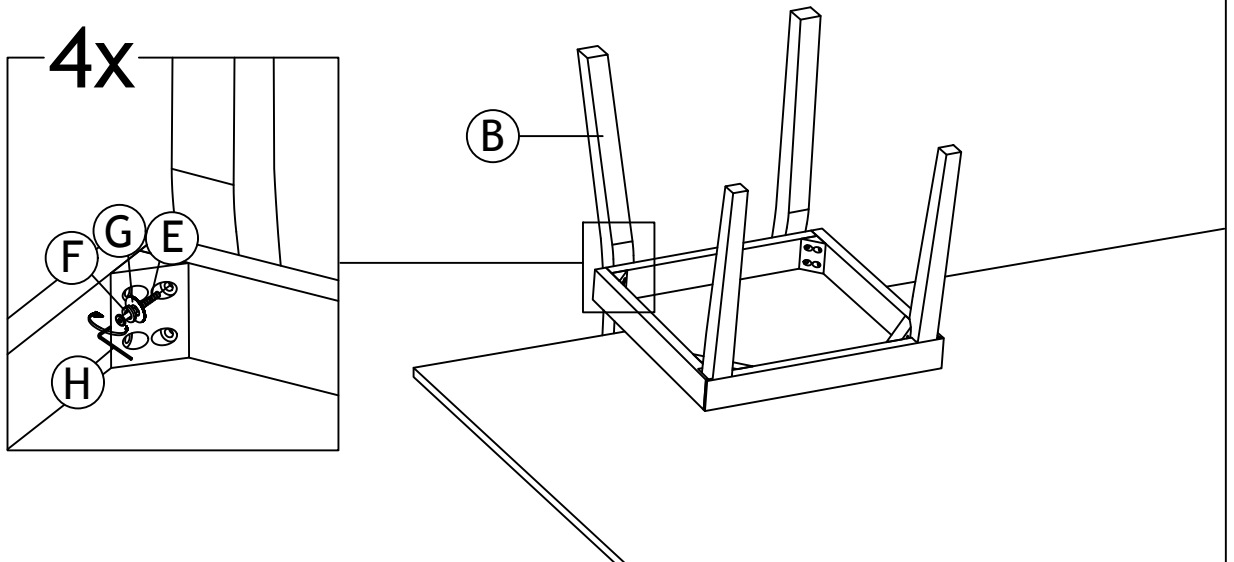

STEP 3

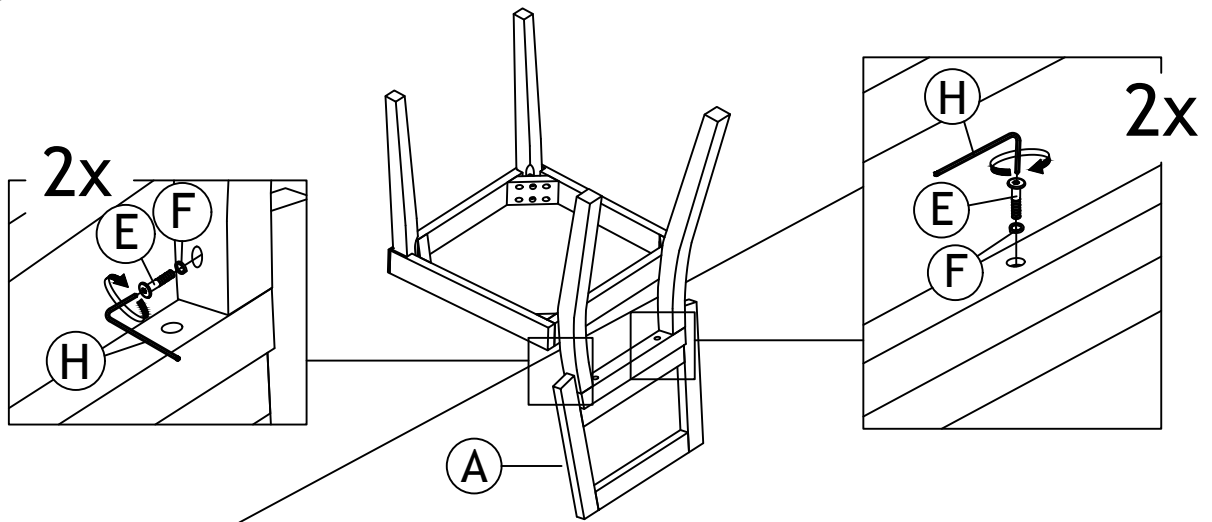

STEP 4

