

**CROSLEY**  
FURNITURE

Hall Tree  
CF6042

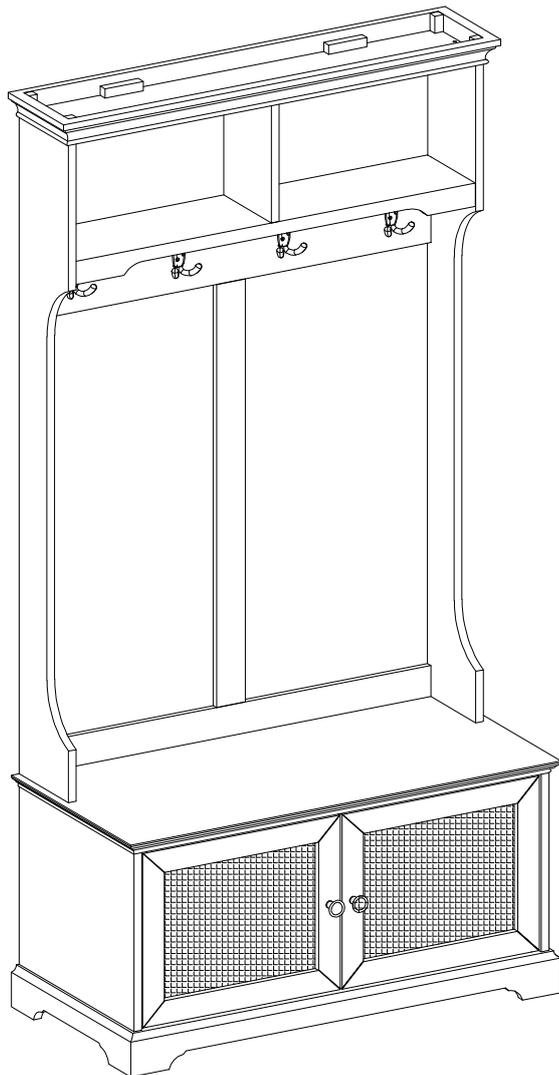
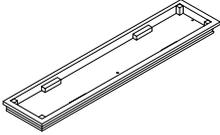
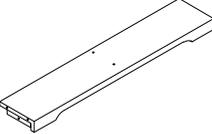
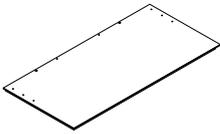
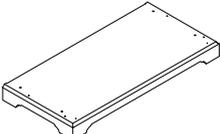
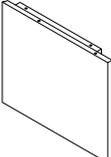
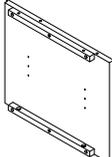
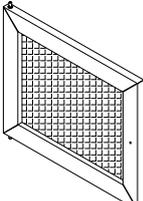
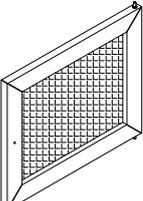
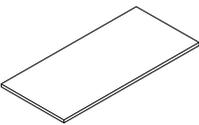
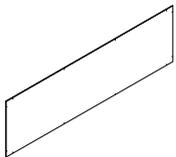
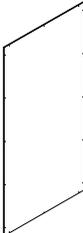
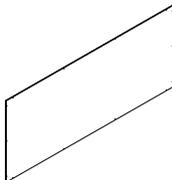
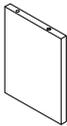
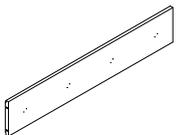
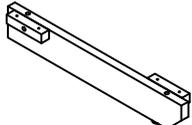

# PART LIST

<p><b>A</b></p> 	<p><b>B</b></p> 	<p><b>C</b></p> 	<p><b>D</b></p> 	<p><b>E</b></p> 
<p>Top Panel 1 PC</p>	<p>Upper Left Panel 1 PC</p>	<p>Upper Right Panel 1 PC</p>	<p>Fixed Shelf 1 PC</p>	<p>Seat Panel 1 PC</p>
<p><b>F</b></p> 	<p><b>G</b></p> 	<p><b>H</b></p> 	<p><b>I</b></p> 	<p><b>J</b></p> 
<p>Bottom Panel 1 PC</p>	<p>Lower Left Panel 1 PC</p>	<p>Lower Right Panel 1 PC</p>	<p>Left Door 1 PC</p>	<p>Right Door 1 PC</p>
<p><b>K2</b></p> 	<p><b>L</b></p> 	<p><b>M</b></p> 	<p><b>N2</b></p> 	<p><b>O</b></p> 
<p>Adjustable Shelf 1 PC</p>	<p>Upper Back Panel 1 PC</p>	<p>Middle Back Panel 2 PCS</p>	<p>Bottom Back Panel 1 PC</p>	<p>Upper Vertical Panel 1 PC</p>
<p><b>P</b></p> 	<p><b>Q</b></p> 	<p><b>R</b></p> 	<p><b>S</b></p> 	
<p>Back Upper Rail 1 PC</p>	<p>Back Lower Rail 1 PC</p>	<p>Back Partition Rail 1 PC</p>	<p>Support Rail 1 PC</p>	

# HARDWARE LIST

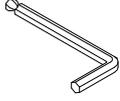
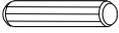
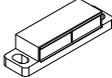
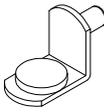
 Ø1/4"*25mm Short Bolt 14 PCS (Extra 1)	 Ø1/4"*51mm Long Bolt 4 PCS (Extra 1)	 Ø1/4"*11mm Spring Washer 18 PCS (Extra 1)	 Ø1/4"*13mm Flat Washer 18 PCS (Extra 1)	 4mm*90 Allen Wrench 1 PC
 Ø8*30mm Wood Dowel 36 PCS (Extra 1)	 Magnet 1 PC	 Knob 2 PCS	 5/32"*25mm Round Head Bolt 2 PCS (Extra 1)	 Hook 4 PCS
 Shelf Holder 4 PCS (Extra 1)	 6*3*12mm Small Screw 8 PCS (Extra 1)	 6*3*15mm Round Head Screw 2 PCS (Extra 1)	 8*3*12mm Medium Screw 44 PCS (Extra 1)	 8*3*15mm Large Screw 14 PCS (Extra 1)
 8*4*25mm Screw 4 PCS (Extra 1)	 Safety Strap Kit 1 SET			

## ADDITIONAL TOOLS (Not Provided)

Note: It is not recommended to use power tools during assembly.



Phillips Head Screwdriver

Note: Wood dowels are intended for alignment. Additional clearance between wood dowel and pre-drilled hole is intentional for ease of assembly.

Please do not use tools to assemble this unit unless specifically indicated.

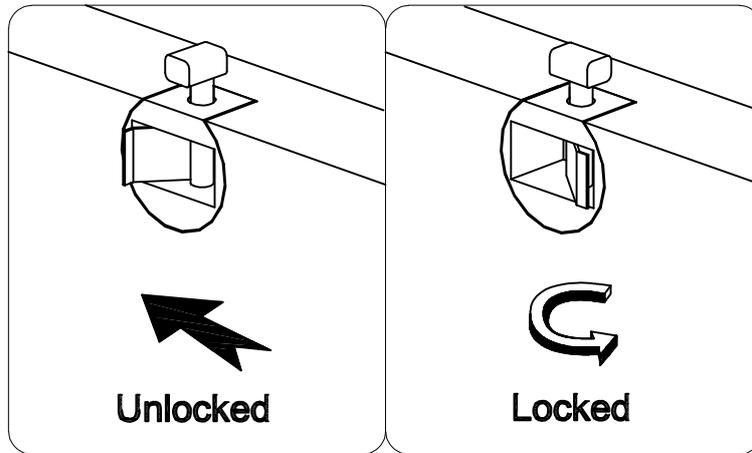

Reference the images above any time the instructions state "lock the hardware"

Note: Be sure to check all hardware is locked when completed.

Step 1. Attach magnet (part #7) to seat panel (part E) using round head screws (part #13) and phillips head screwdriver.

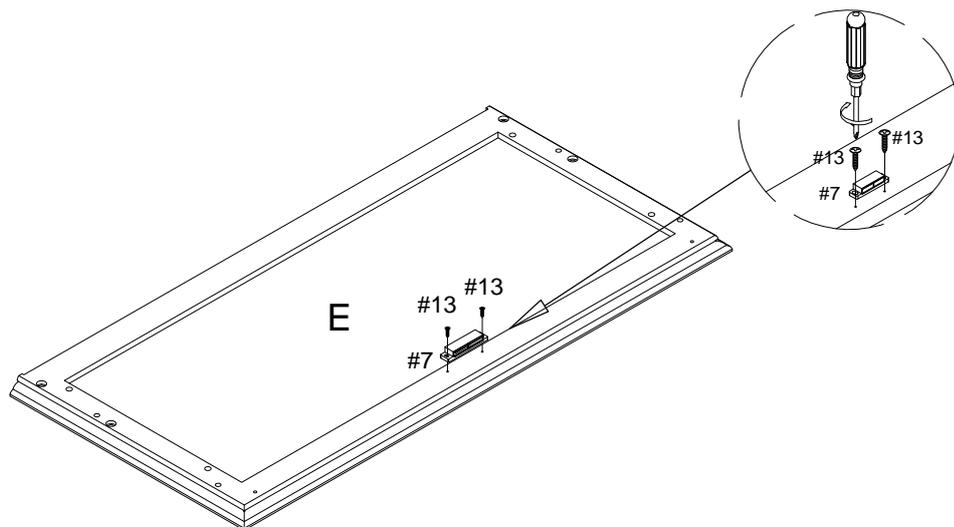

- #7  x 1
- #13  x 2

Step 2. Attach hooks (part #10) to back upper rail (part P) using small screws (part #12) and phillips head screwdriver.

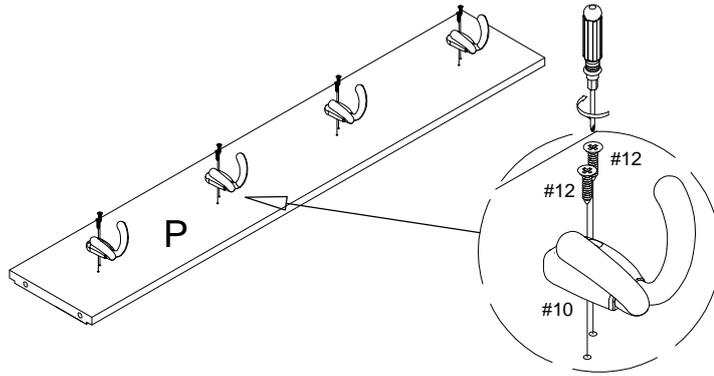

- #10  x 4
- #12  x 8

Step 3. Attach support rail (part S) to bottom panel (part F) using wood dowels (part #6) , screws (part #16) and phillips head screwdriver.

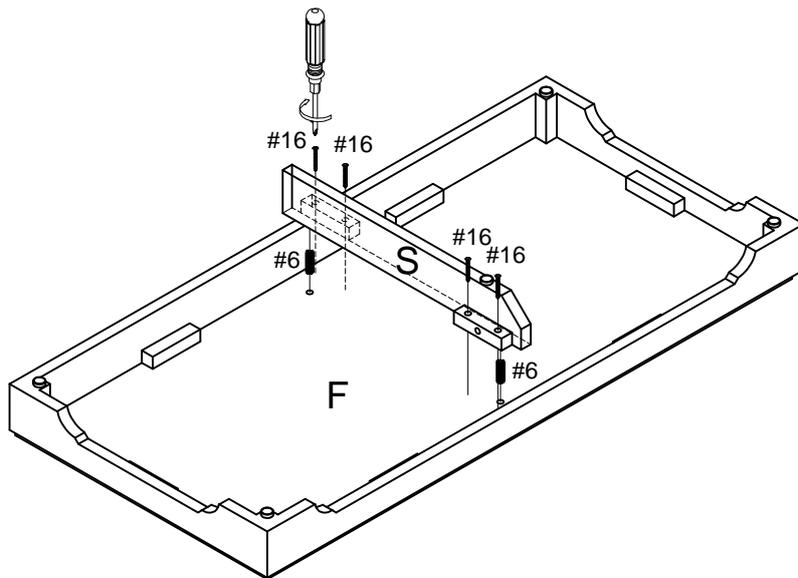

- #6  x 2
- #16  x 4

Step 4. Attach knobs (part #8) to doors (parts I & J) using round head bolts (part #9) and phillips head screwdriver.

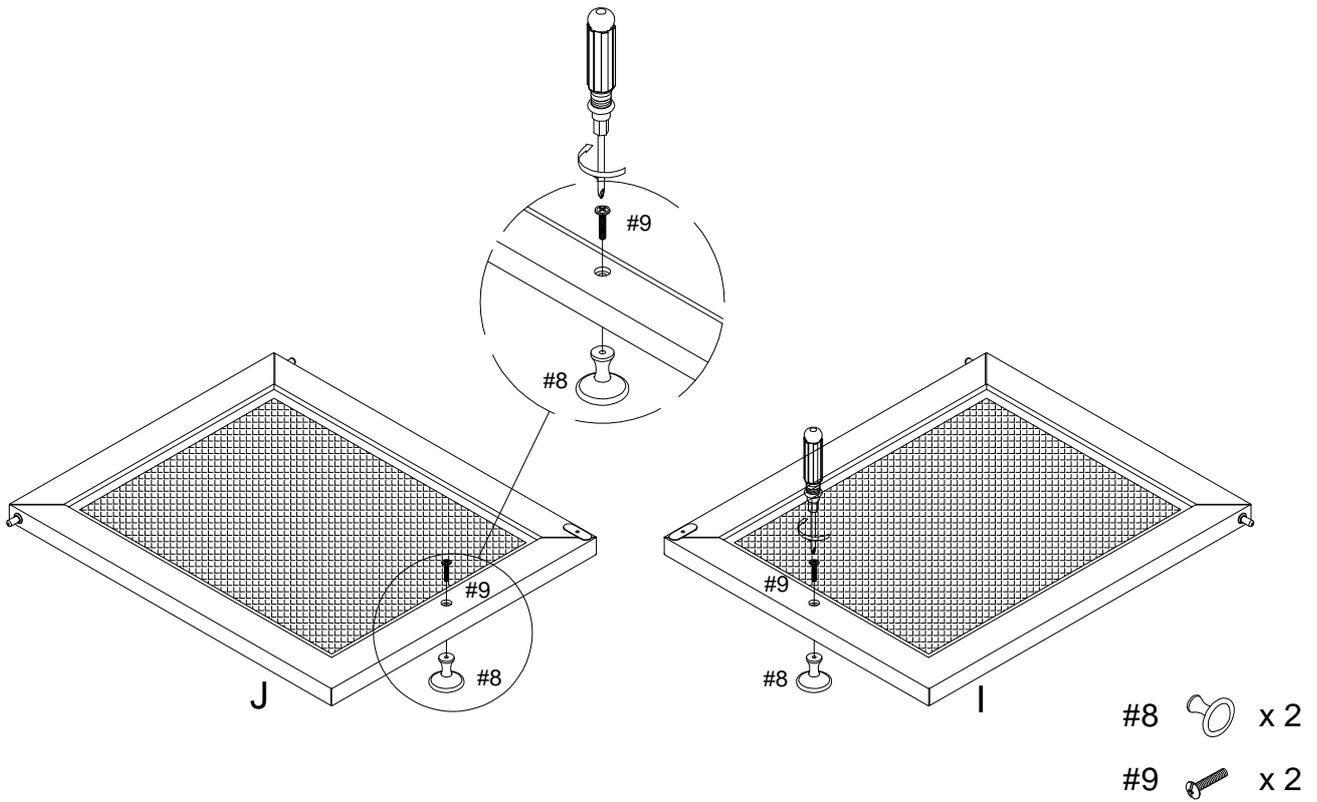

Step 5. Attach back upper rail (part P) and back lower rail (part Q) to back partition rail (part R) using wood dowels (part #6).

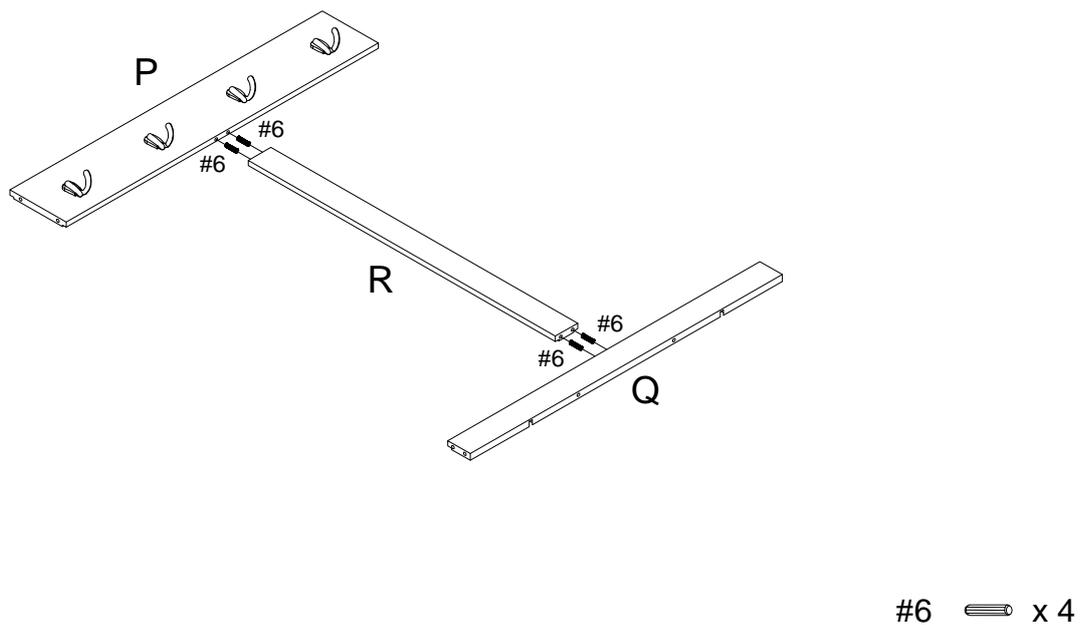

Step 6. Line up fixed shelf (part D) with back upper rail (part P). Attach upper right panel (part C) to panels (parts D, P & Q) using wood dowels (part #6), short bolt (part #1), spring washer (part #3), flat washer (part #4) and allen wrench (part #5).

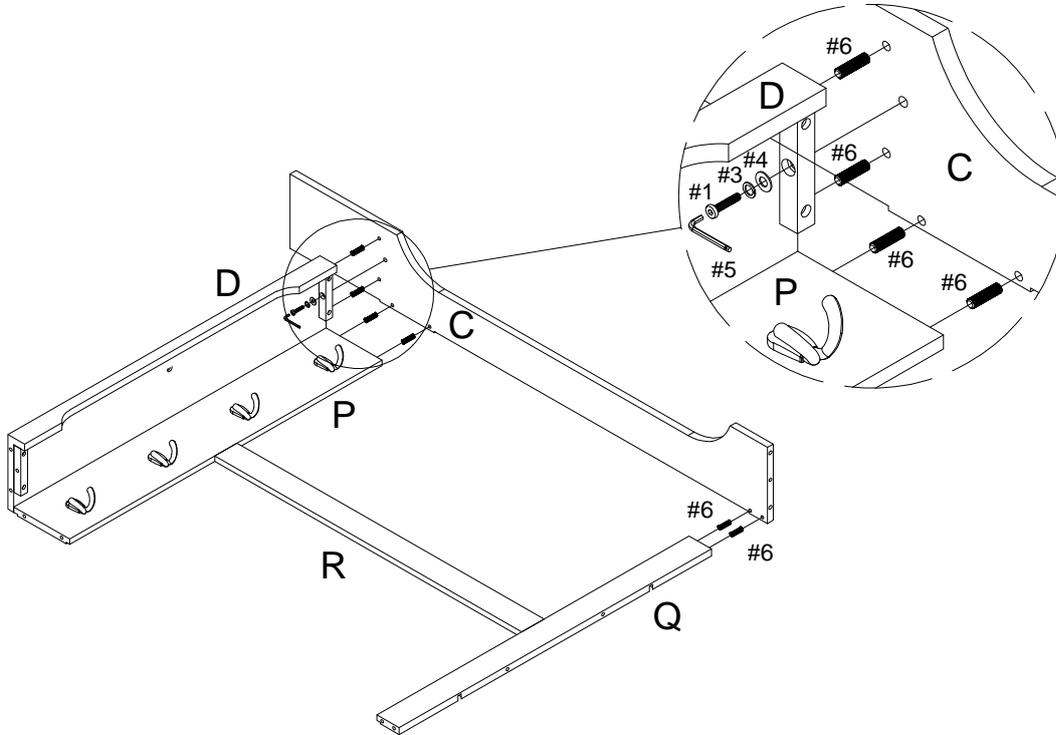

- #1  x 1
- #3  x 1
- #4  x 1
- #5  x 1
- #6  x 6

Step 7. Attach upper left panel (part B) to panels (parts D, P & Q) using wood dowels (part #6), short bolt (part #1), spring washer (part #3), flat washer (part #4) and allen wrench (part #5).

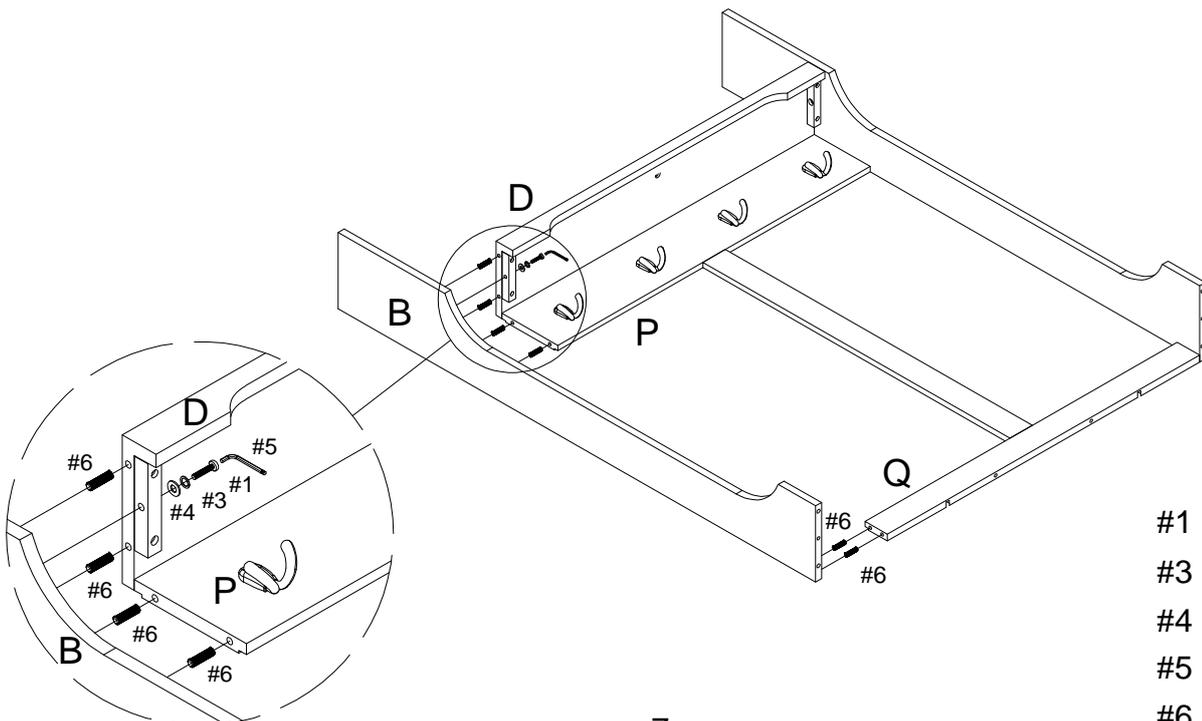

- #1  x 1
- #3  x 1
- #4  x 1
- #5  x 1
- #6  x 6

Step 8. Attach upper vertical panel (part O) to fixed shelf (part D) using wood dowel (part #6), short bolt (part #1), spring washer (part #3), flat washer (part #4) and allen wrench (part #5). Attach top panel (part A) to panels (parts B, C & O) using wood dowels (part #6), short bolts (part #1), spring washers (part #3), flat washers (part #4) and allen wrench (part #5).

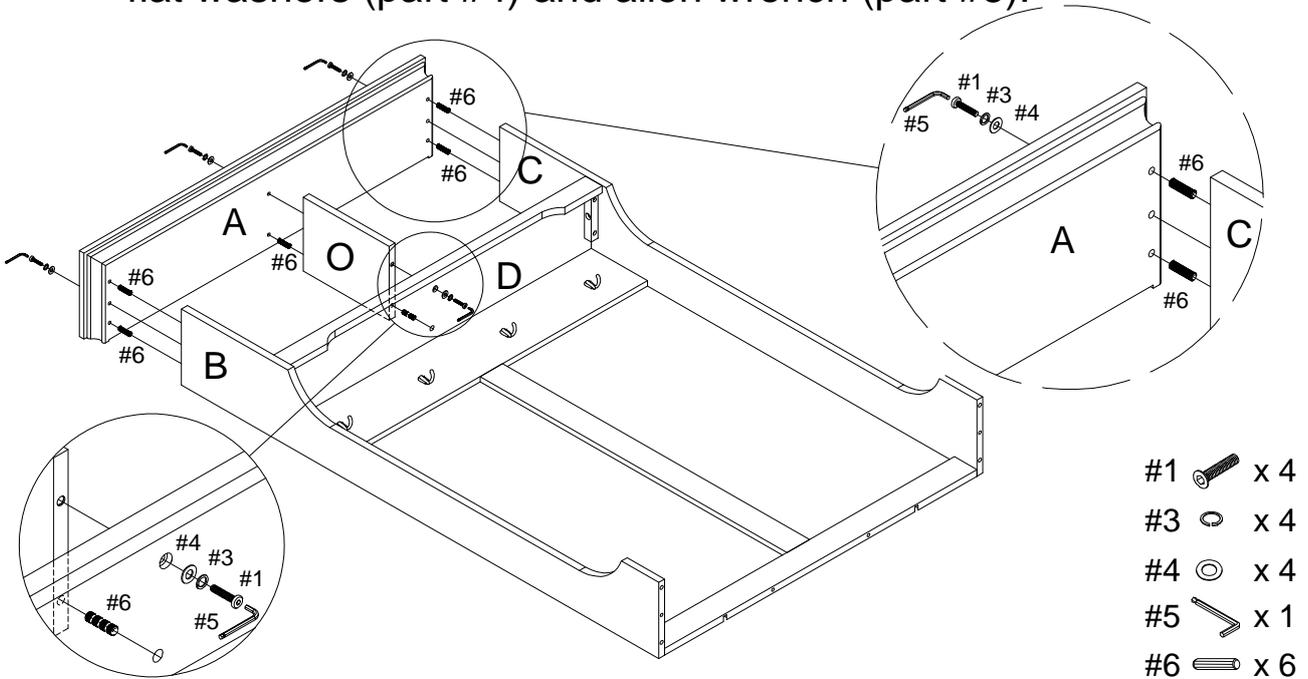

Step 9. Attach seat panel (part E) to assembled unit (parts B, C & Q) using wood dowels (part #6), long bolts (part #2), spring washers (part #3), flat washers (part #4) and allen wrench (part #5).

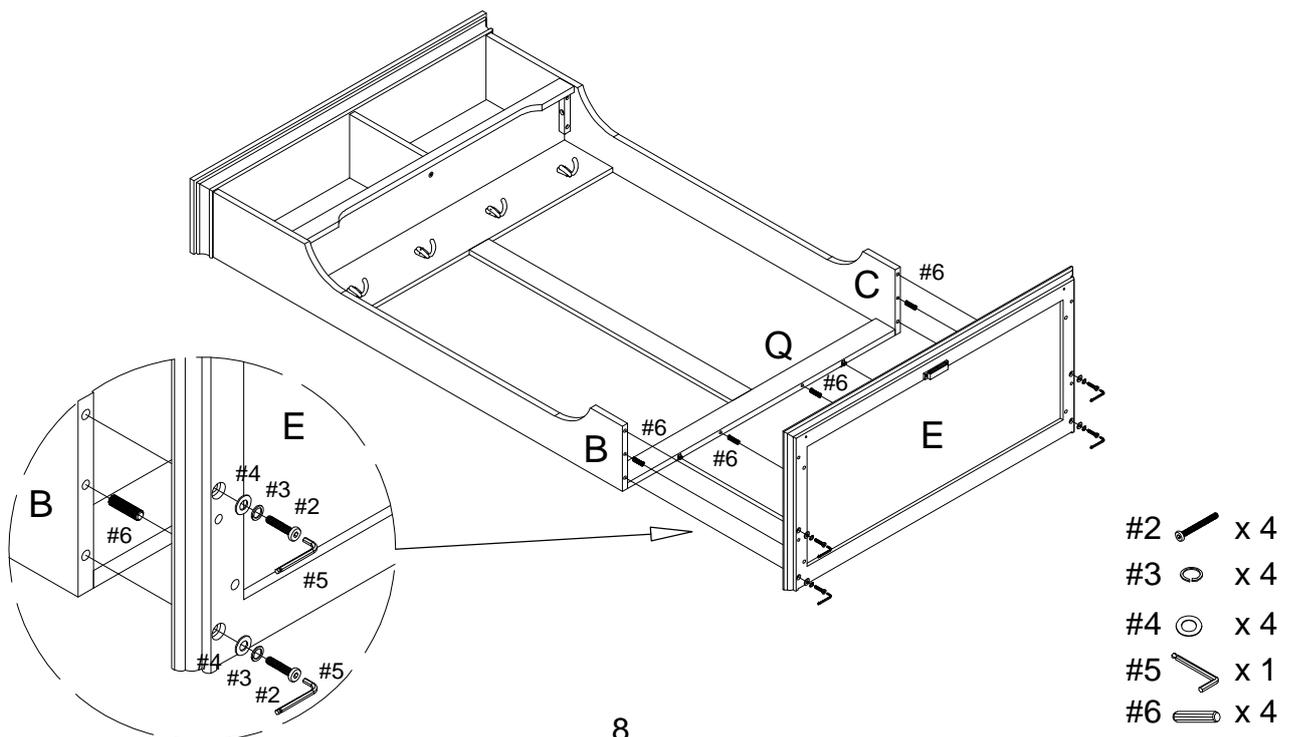

Step 10. Attach lower panels (parts G & H) to seat panel (part E) using wood dowels (part #6), short bolts (part #1), spring washers (part #3), flat washers (part #4) and allen wrench (part #5).

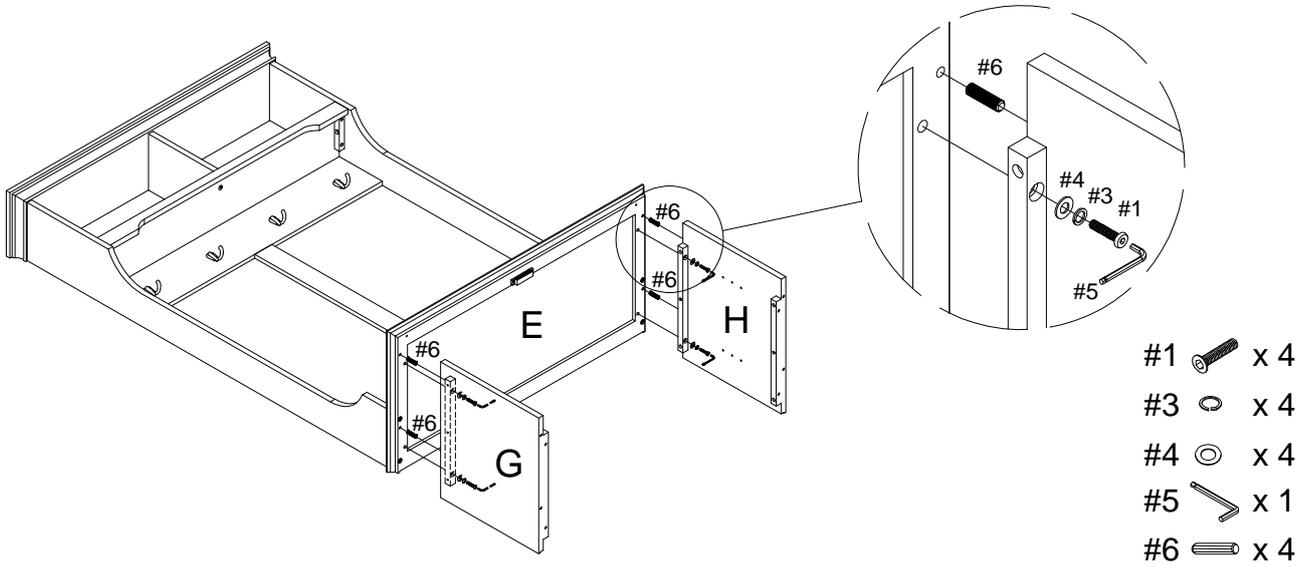

Step 11. Attach bottom panel (part F) to lower panels (parts G & H) using wood dowels (part #6), short bolts (part #1), spring washers (part #3), flat washers (part #4) and allen wrench (part #5).

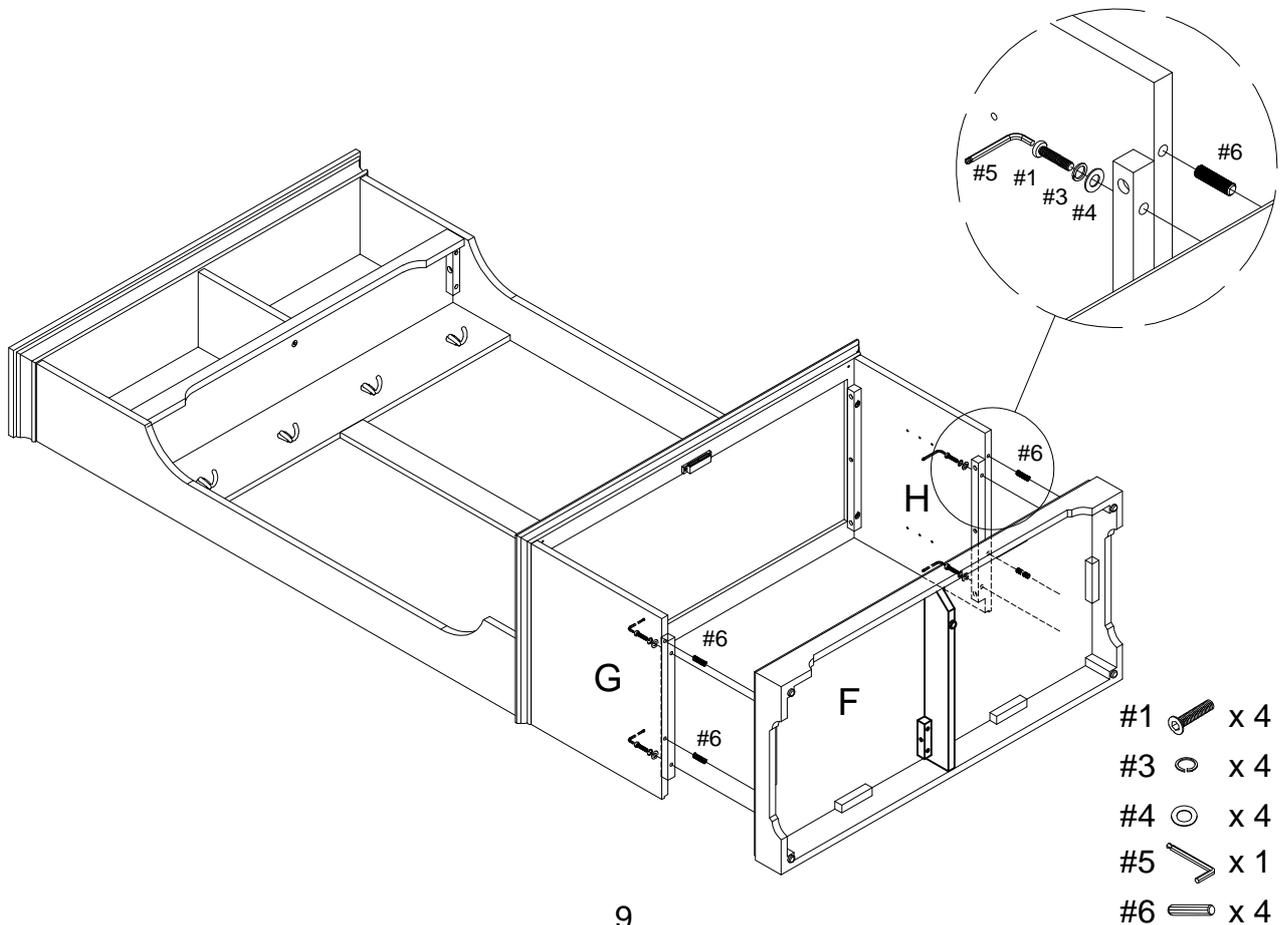

Step 12. Carefully turn unit upright. Lock the hardware on back lower rail (part Q).

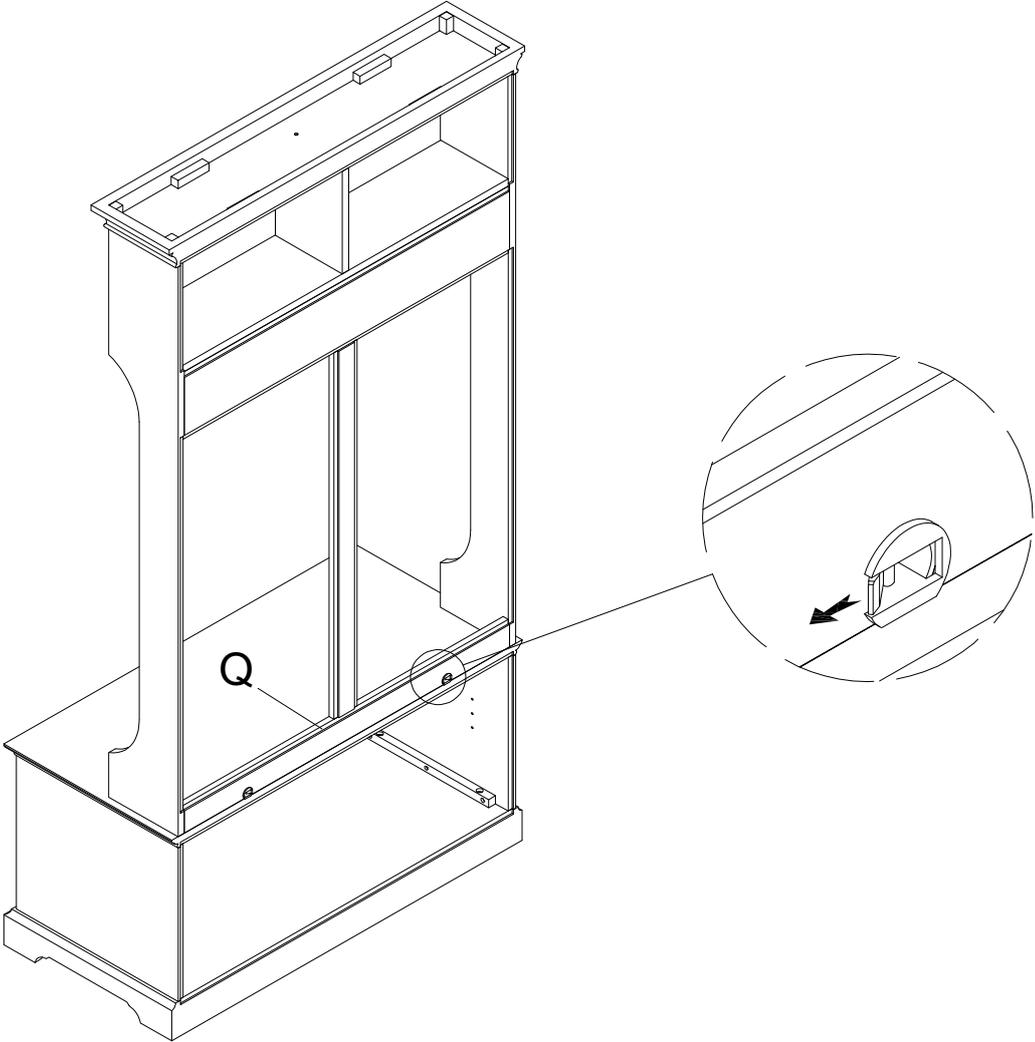

Step 13. Attach upper back panel (part L) to assembled unit (parts A, B, C & P) using medium screws (part #14) and phillips head screwdriver.

Attach middle back panels (part M) to assembled unit (parts B, C, P, Q & R) using medium screws (part #14) and phillips head screwdriver.

Attach bottom back panel (part N2) to assembled unit (parts E, F, G & H) using large screws (part #15) and phillips head screwdriver.

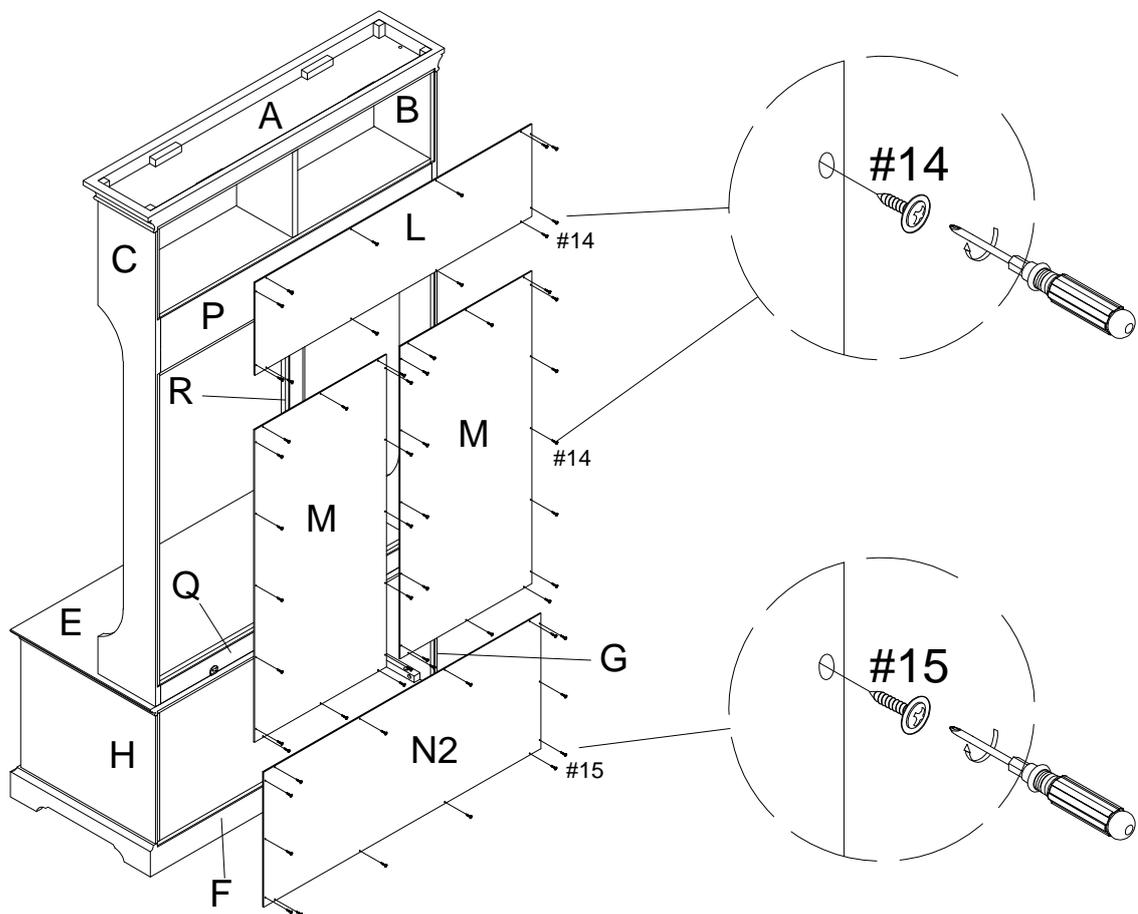

#14  x 44

#15  x 14

Step 14. Attach doors (parts I & J) by placing pin hinge (pre-installed in door) in the pre-drilled hole of bottom panel (part F). Then depress the top spring-loaded pin hinge so it can be placed in the pre-drilled hole of seat panel (part E).

NOTE: Be sure top and bottom pin hinges are fully extended to secure doors in place.

NOTE: It is important to adjust levelers once fully assembled and upright. Extend adjustable leveler until it's firmly in contact with the floor. If relocating, adjust leveler as needed until it's firmly in contact with the floor in new location.

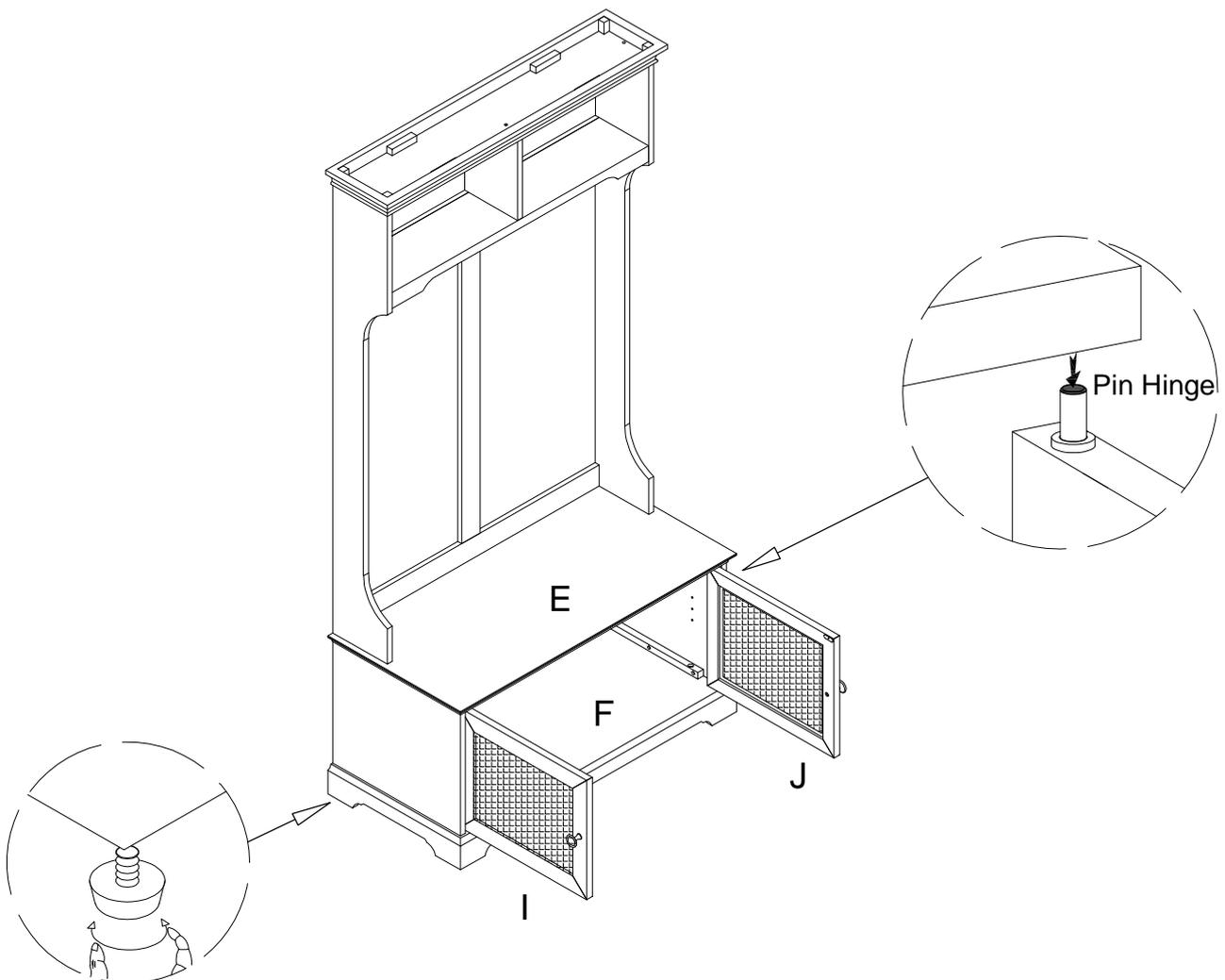

Step 15. Place shelf holders (part #11) into desired position, slide adjustable shelf (part K2) into place.  
Important: Safety strap kit (part #15) must be installed to prevent tipping, damage and/or injury.

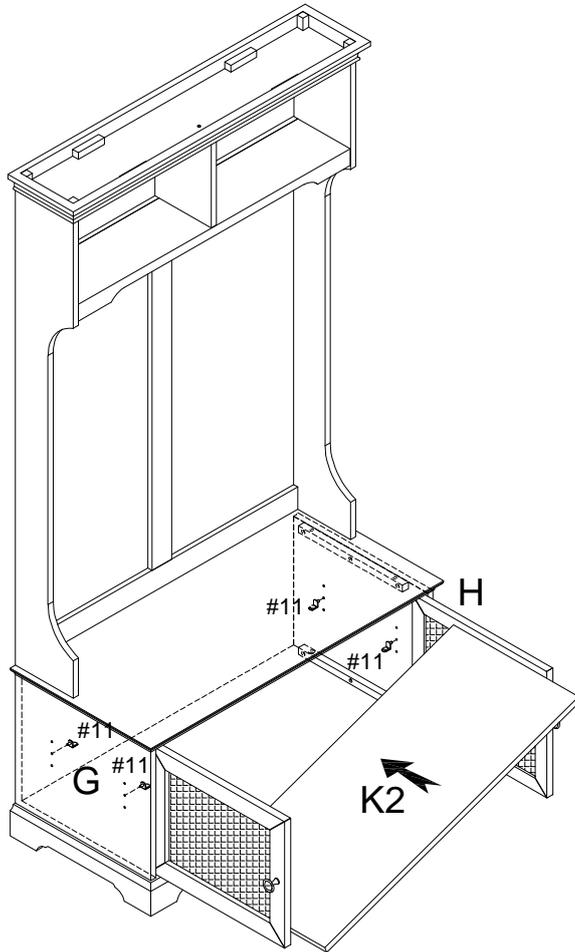

#11  x 4

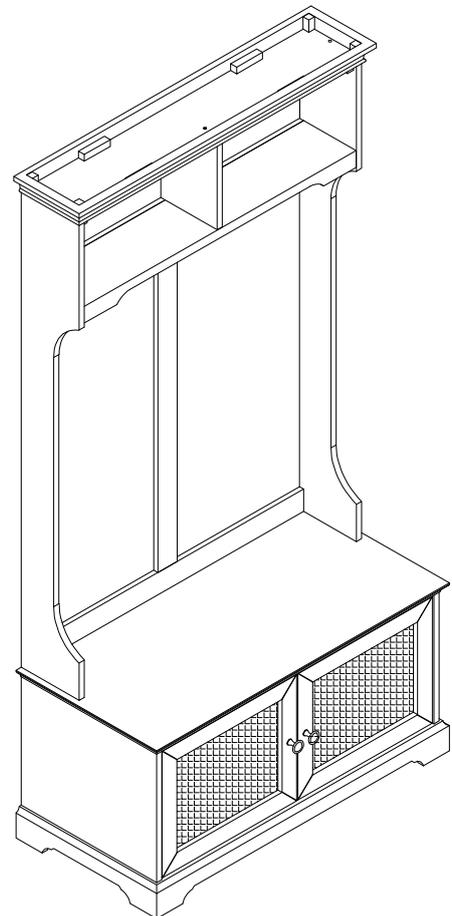

#17	A	B	C	D	E
					
Safety Strap Kit 1 SET	Wall Anchor 1 PC	Bracket 2 PCS	Short Screw 1 PC	Long Screw 1 PC	Safety Wall Strap 1 PC

## SAFETY WALL STRAP INSTALLATION

Note: It is highly recommended to install this safety strap kit to prevent tipping, damage and/or injury.

1. Insert short screw (C) and safety wall strap (E) through bracket (B) and attach to top panel (part A) using phillips head screwdriver.
2. Drill a 11/32" hole where you want to secure the unit. The drilled hole will be at the same height as the hole in top panel (part A) where bracket (B) is attached. Tap wall anchor (A) into the hole.
3. Insert long screw (D) and safety wall strap (E) through bracket (B) into wall anchor (A) using phillips head screwdriver.

Note: This item is not intended for clothing storage use.

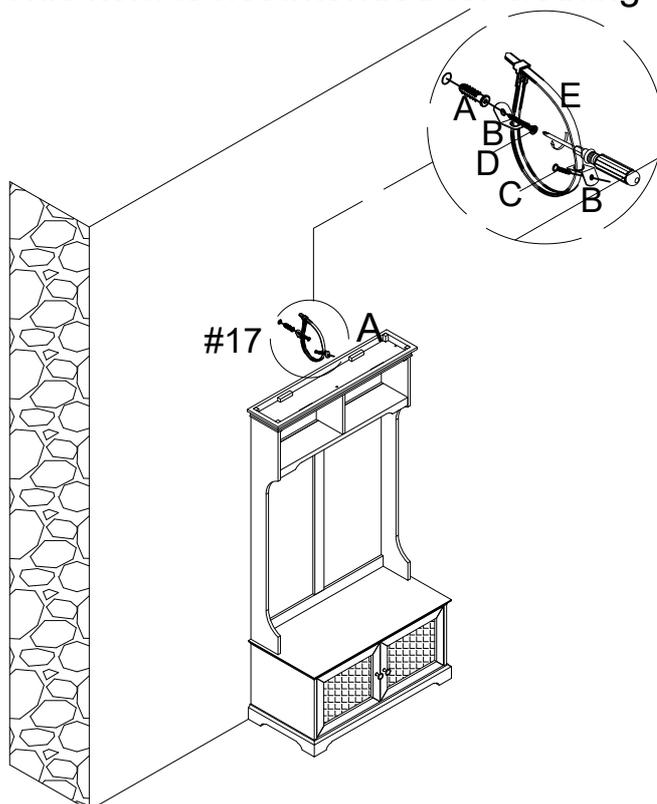

▲WARNING	
	Children have died from furniture tipover. To reduce the risk of furniture tipover:
	<ul style="list-style-type: none"> <li>• ALWAYS install tipover restraint provided.</li> <li>• NEVER put a TV on this product.</li> <li>• NEVER allow children to stand, climb or hang on drawers, doors, or shelves.</li> <li>• NEVER open more than one drawer at a time.</li> <li>• Place heaviest items in the lowest drawers.</li> </ul>
<i>This is a permanent label. Do not remove!</i>	