

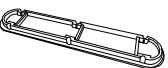

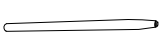



# ASSEMBLY INSTRUCTIONS

CVFDR1039

## PARTS

S.NO.	DESCRIPTION	QNT
A	 TOP	01
B	 LEGS	06
C	 SHELF	01

## HARDWARE

S.NO.	DESCRIPTION	QNT
D	 WASHER	18
E	 SPRING WASHER	18
F	 JCBC M6 x 40	18
G	 ALLEN KEY	01

### STEP - 1

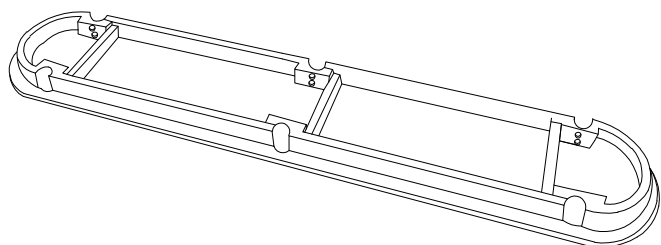

put the TOP (A) on the floor upside down

### STEP - 2

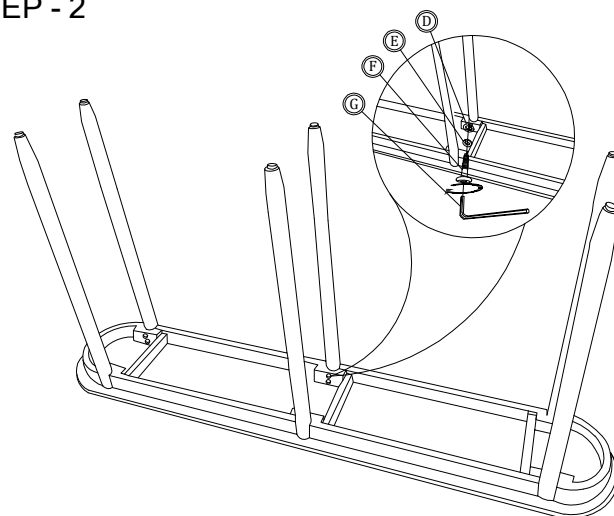

Attach to the 6 legs (B), adjust to the mount on the top(A), then attach the JCBC M6 x 40 (F) with washer (D) and spring washer (E), tighten with allen key (G)

### STEP - 3

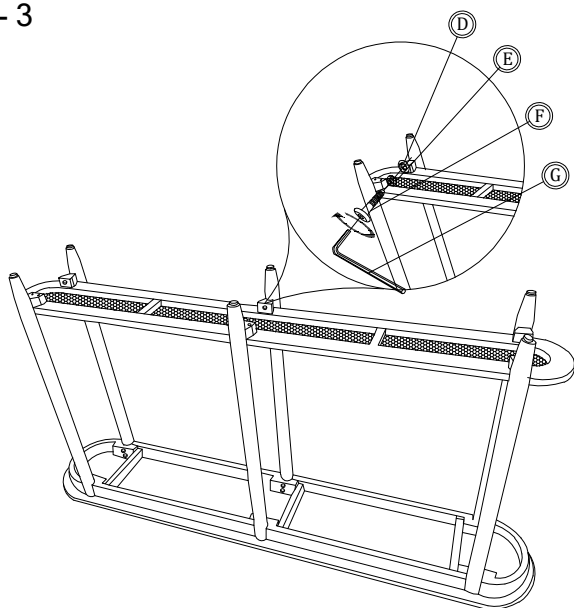

Install the shelf (C) on the legs according to the hole in the leg, Install the JCBC M6 x 40 (F) along with the washer (D) and spring washer (E), (tighten with an allen key (G))

### COMPLETED

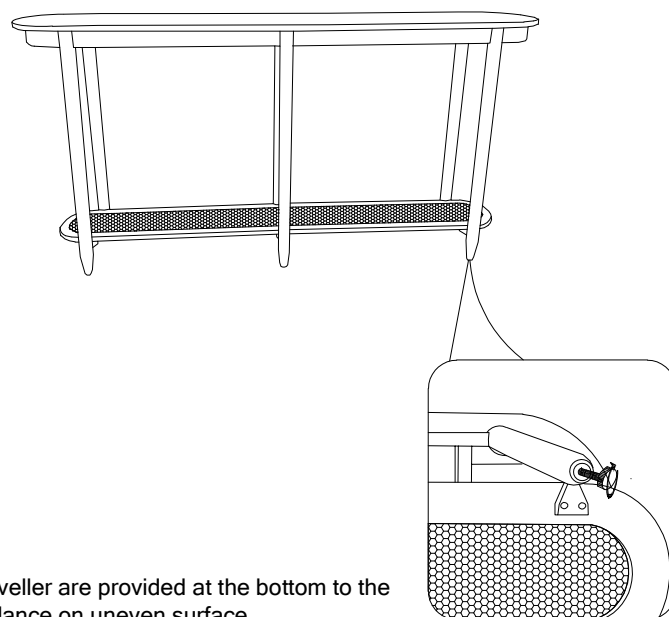





Leveller are provided at the bottom to the balance on uneven surface

MADE IN INDONESIA

# ANTI - TIP KIT INSTALLATION INSTRUCTIONS

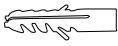
## CVFDR1039\_CONSOLE TABLE

- A : 1X 
- B : 2X 
- C : 2X  S5
- D : 2X 
- E : 2X 

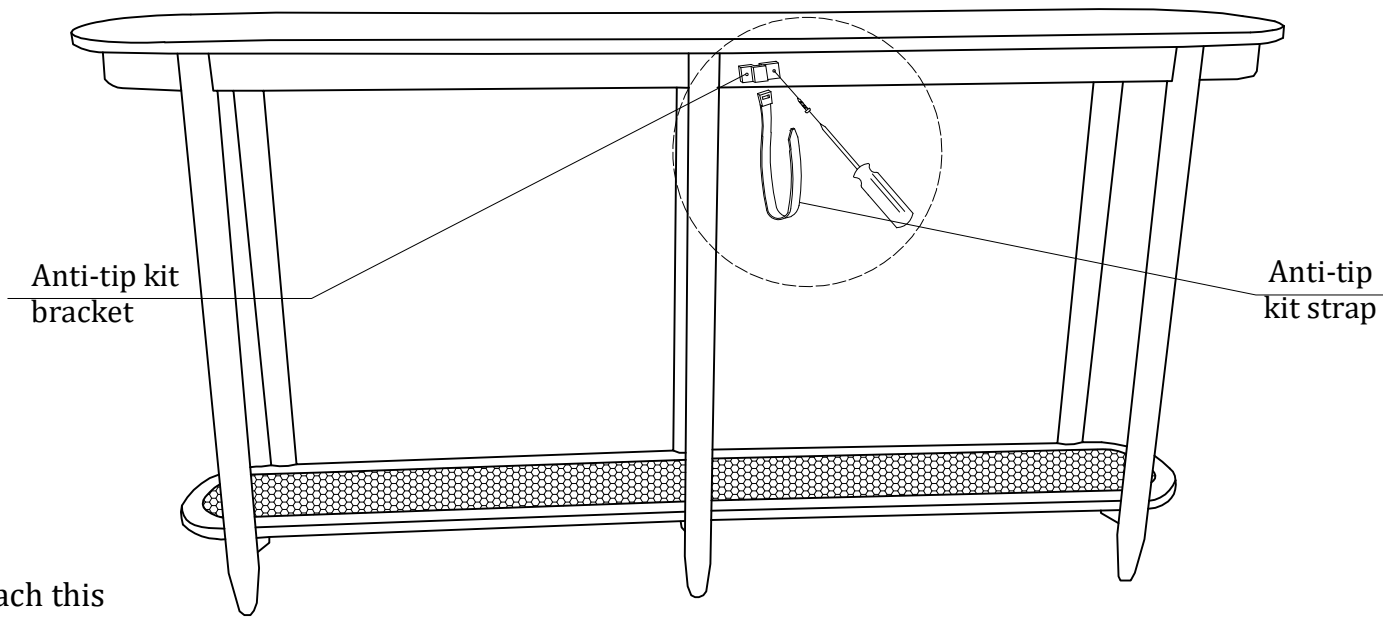
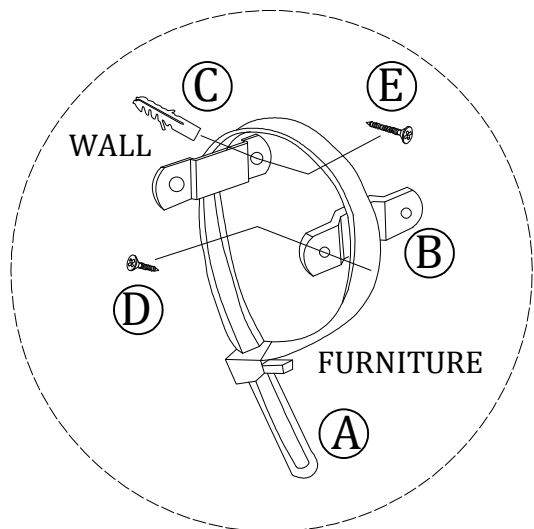

Attach this bracket to furniture

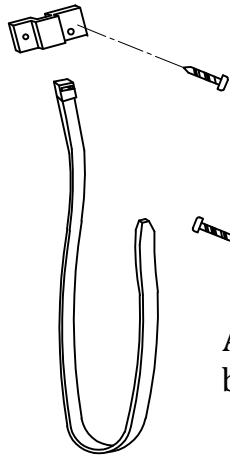

**i**

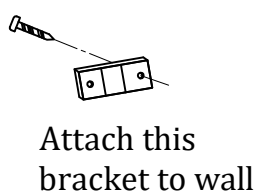

Attach this bracket to wall

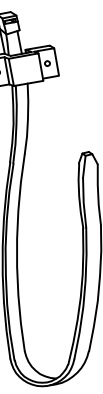

**ii**

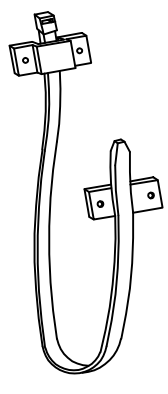

**iii**

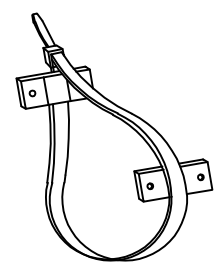

**iv**