

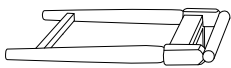





# ASSEMBLY INSTRUCTIONS

CVFDR1032

## PARTS

S.NO.	DESCRIPTION	QNT
A	 TOP	01
B	 LEGS	02
C	 STRETCHER	01

## HARDWARE

S.NO.	DESCRIPTION	QNT
D	 WASHER	08
E	 SPRING WASHER	08
F	 JCBC M6 x 30	06
G	 JCBC M6 x 20	02
H	 ALLEN KEY	01

### STEP - 1

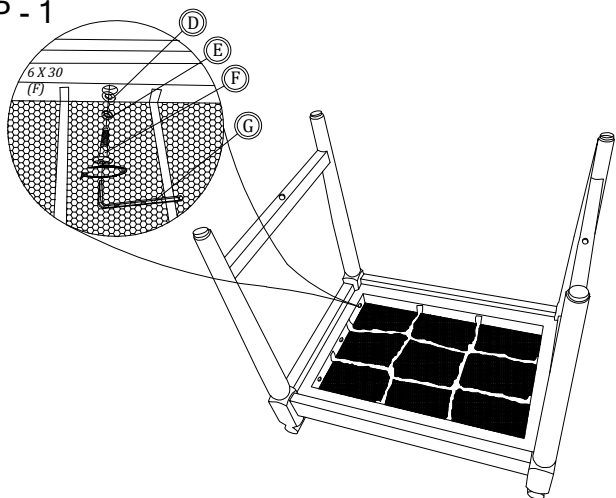

Place the top (A) on the floor upside down, attach to the two legs (B)  
Install the Washer (D), Spring washer (E) and JCBC ( M6 x 30 ) (F)  
(tighten with allen key (H)

### STEP - 2

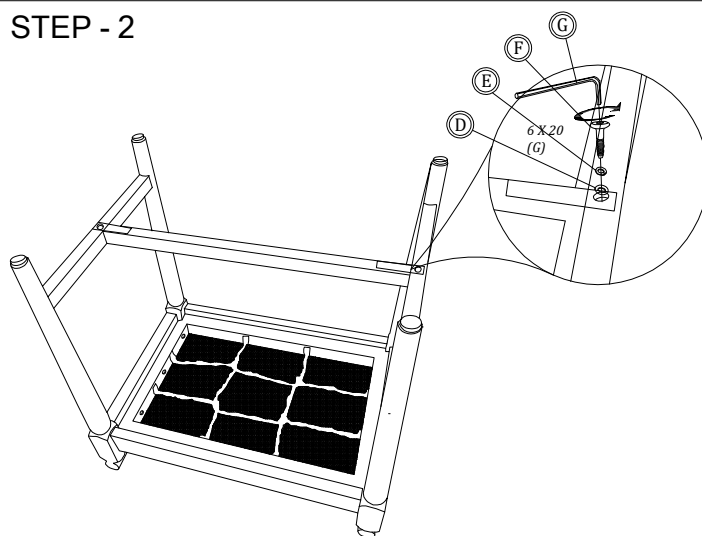

Install the stretcher (C) on the leg mount (B), Install the  
Washer (D), Spring washer (E), JCBC (M6 x 20) (G)  
Tighten with allen key (H)

### COMPLETED

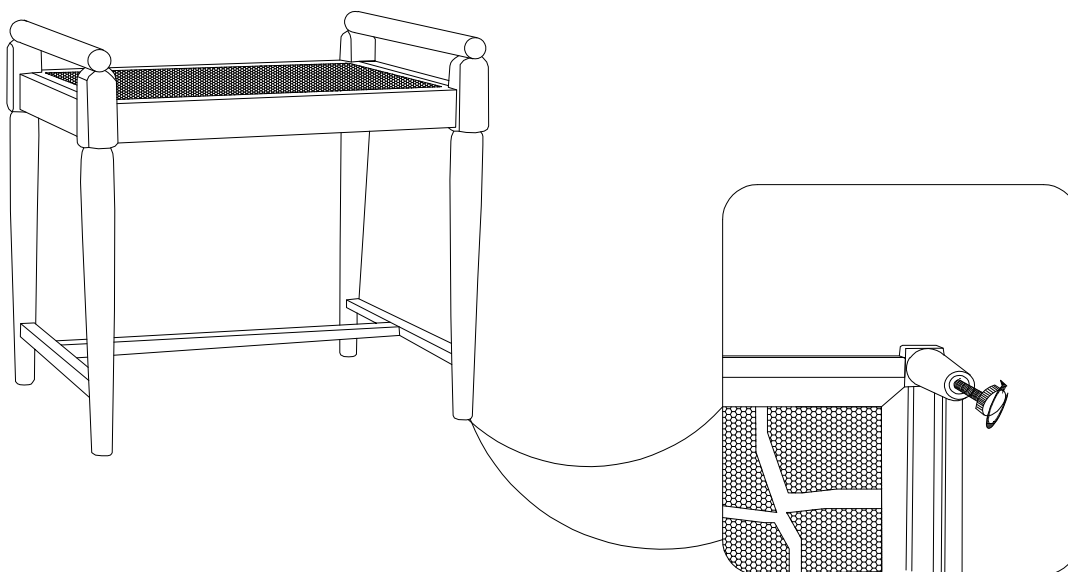

Leveller are provided at the bottom to the  
balance on uneven surface

MADE IN INDONESIA