

WORLD MARKET®

Assembly Instructions

Campaign Bookshelf Light Walnut WD

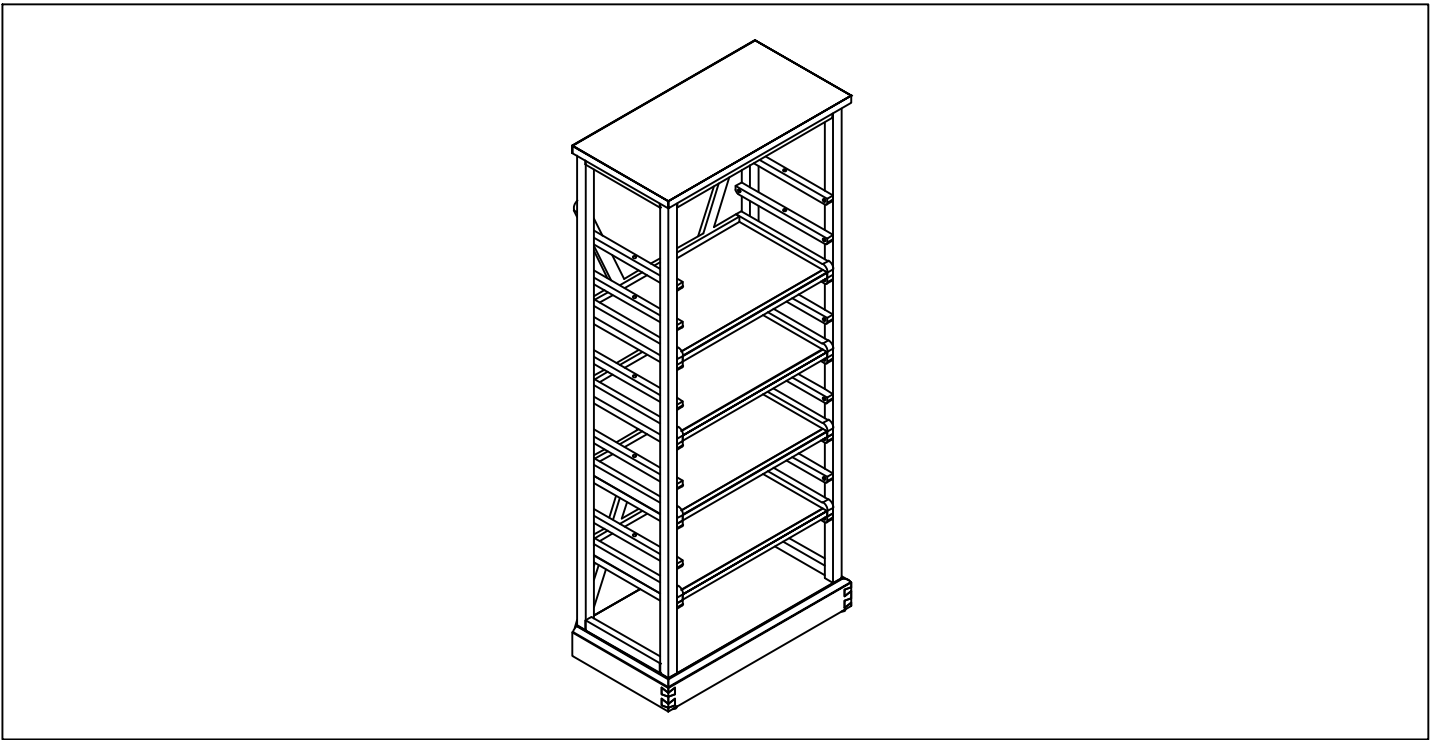

SKU 637648







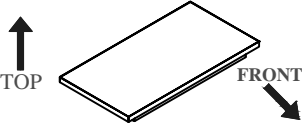
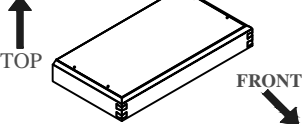
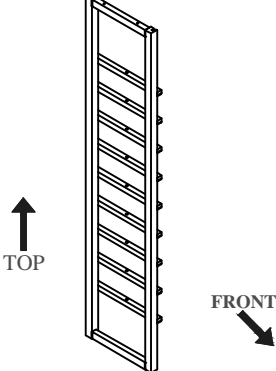
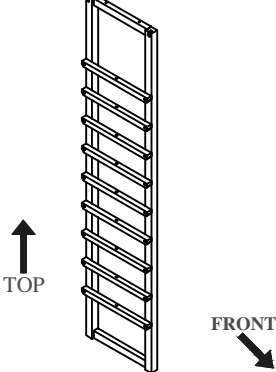

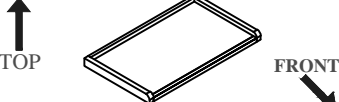
Thank you for your purchase. If you have any questions pertaining to the assembly of this furniture piece, please contact the nearest World Market store. If you are not near a store, please call our customer service call center toll free at 877-967-5362 for assistance.

ALL PRODUCTS SOLD AT WORLD MARKET ARE NOT
FOR COMMERCIAL USE AND ARE INTENDED FOR
RESIDENTIAL USE ONLY

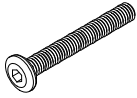
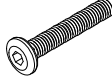

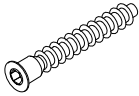
Component List

LABEL	PICTURE	DESCRIPTION	QTY.
A		Top Frame	1
B		Bottom Frame	1
C-1		Left Side Frame	1
C-2		Right Side Frame	1
D		Support	2
E		Shelf Frame	4

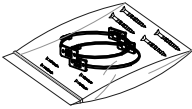
Hardware List

LABEL	PICTURE	DESCRIPTION	QTY.
H-1		Long Allen Bolt M6 x 45mm	8
H-2		Medium Allen Bolt M6 x 35mm	4
H-3		Lock Washer Ø6 x Ø10.5 x 1mm	12
H-4		Small Flat Washer Ø6 x Ø13 x 1mm	12
H-5		Connecting Screw M7 x 50 mm	8
H-6		Short Allen Bolt M8 x 25mm	1
H-7		Nut M8 x 13mm	1
H-8		Large Flat Washer Ø8 x Ø19 x 1mm	2
H-9		Anti Tip-kit	1

Tool List

LABEL	PICTURE	DESCRIPTION	QTY.
T-1		Allen Key 4 x 110 x 30 mm	1
T-2		Triangle	1

Assembly Preparation

Before Beginning:

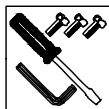
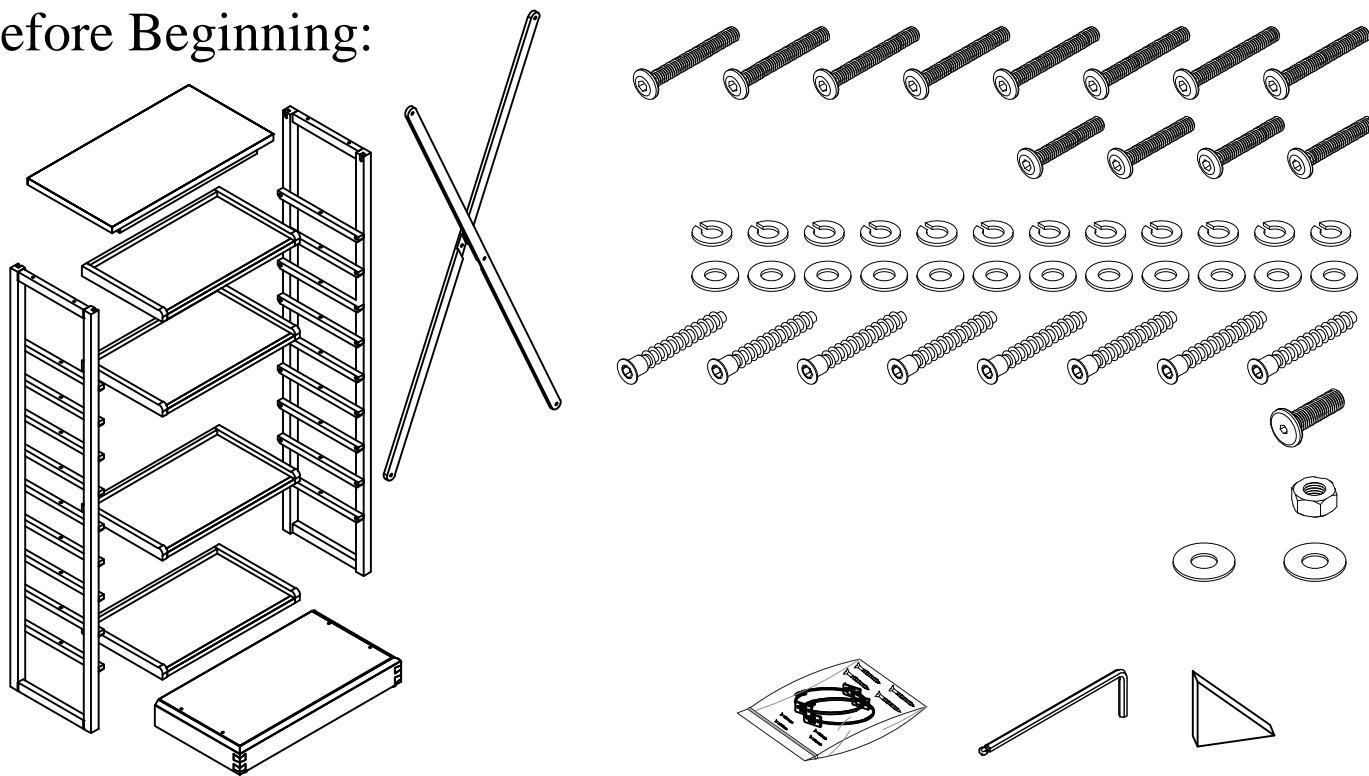

Unpack all hardware bags and components to ensure you have all parts. Take note of bolt hardware size differences and components that may have directional labels (Example: TOP or FRONT).



Read the assembly instructions, cover-to-cover. Save any **Care and Maintenance** instructions pages for after the assembly has been completed.



It is always recommended to have 2 adults on hand for assembly.



Do not assemble on hard, abrasive flooring or carpeted surfaces that can damage or get caught in the components during assembly.

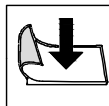

Assemble on a clean non-marring surface (such as the product's packing foam).

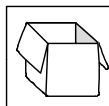

Do not discard any packaging until the product has been fully assembled.



In case of missing parts, please contact your nearest World Market store or call our customer service call center at 1-877-967-5362.



WARNING: Small parts are a choking hazard. Adult supervision is required before, during, and after assembly.

Assembly Steps

Step 1

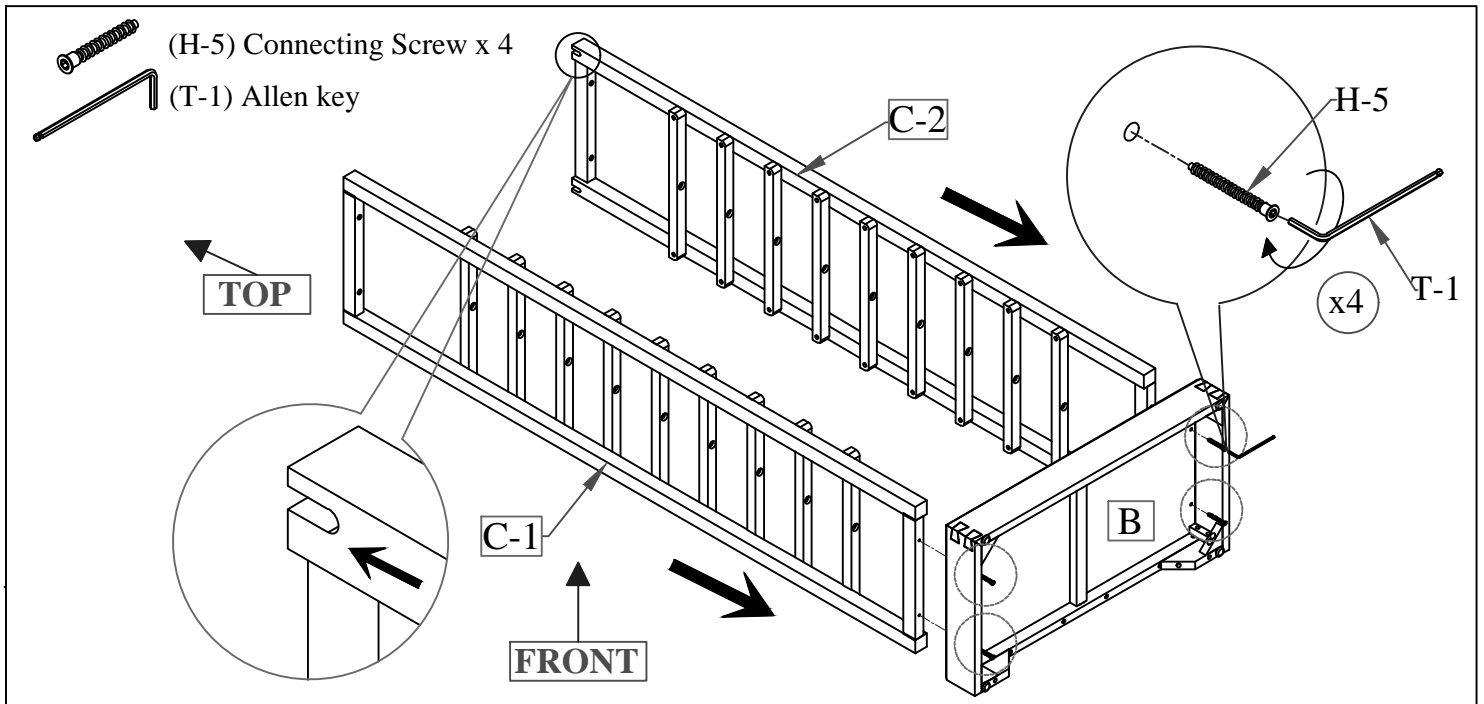

Using a second person to assist you, place the Bottom Frame (B) on its back onto a padded, non-marring surface. Position the Left/Right Side Frames (C-1/C-2) with the Bottom Frame (B), as shown above, ensuring they are oriented correctly. Secure the connections using Connecting Screws (H-5) using the provided Allen Key (T-1). Engage all hardware first, then fully tighten. **DO NOT OVER TIGHTEN.**

Step 2

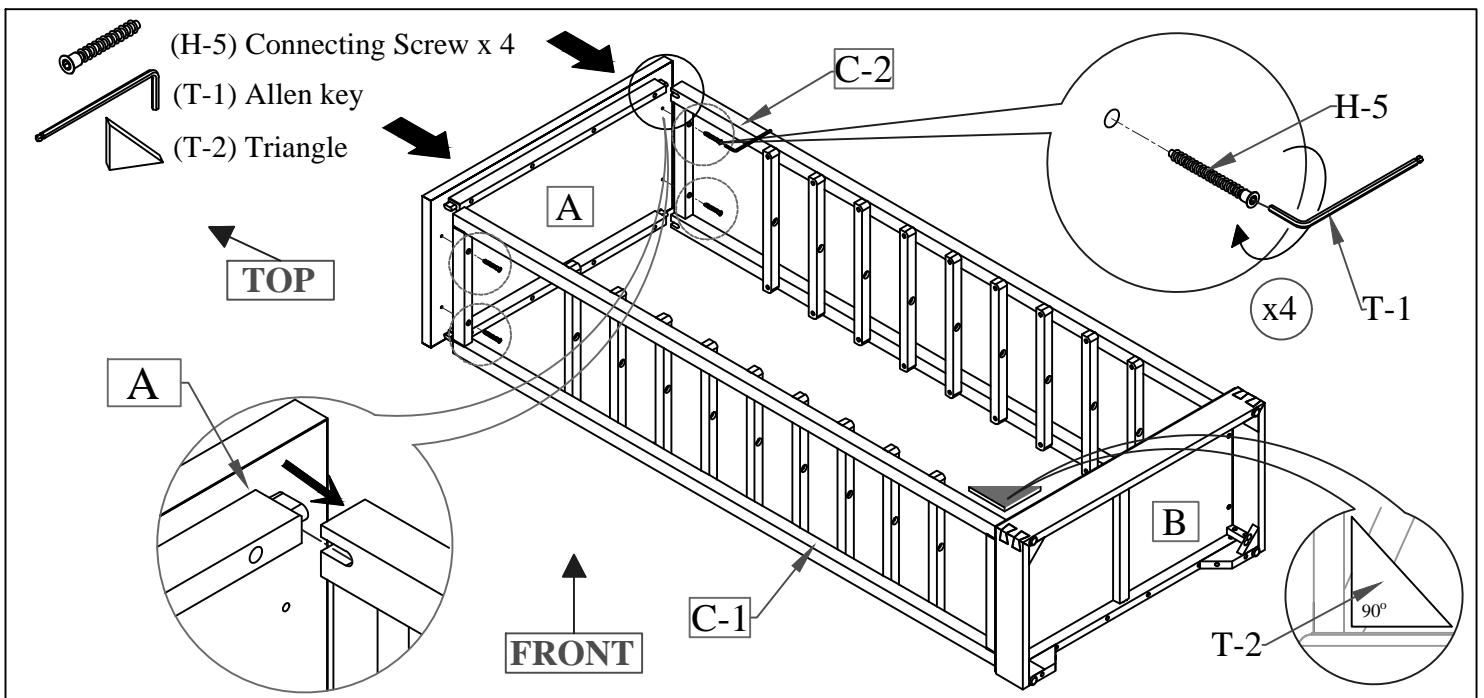

Position the Top Frame (A) with the top of the assembly in the correct direction, careful not to move the Left/Right Side Frames (C-1/C-2) to avoid breakage. Secure the connections with Connecting Screws (H-5) using the provided Allen Key (T-1). Engage all hardware first, then fully tighten. **DO NOT OVER TIGHTEN.** Check that the assembly is square (90 degrees) using the provided Triangle (T-2). Adjust assembly until you are satisfied.

Step 3

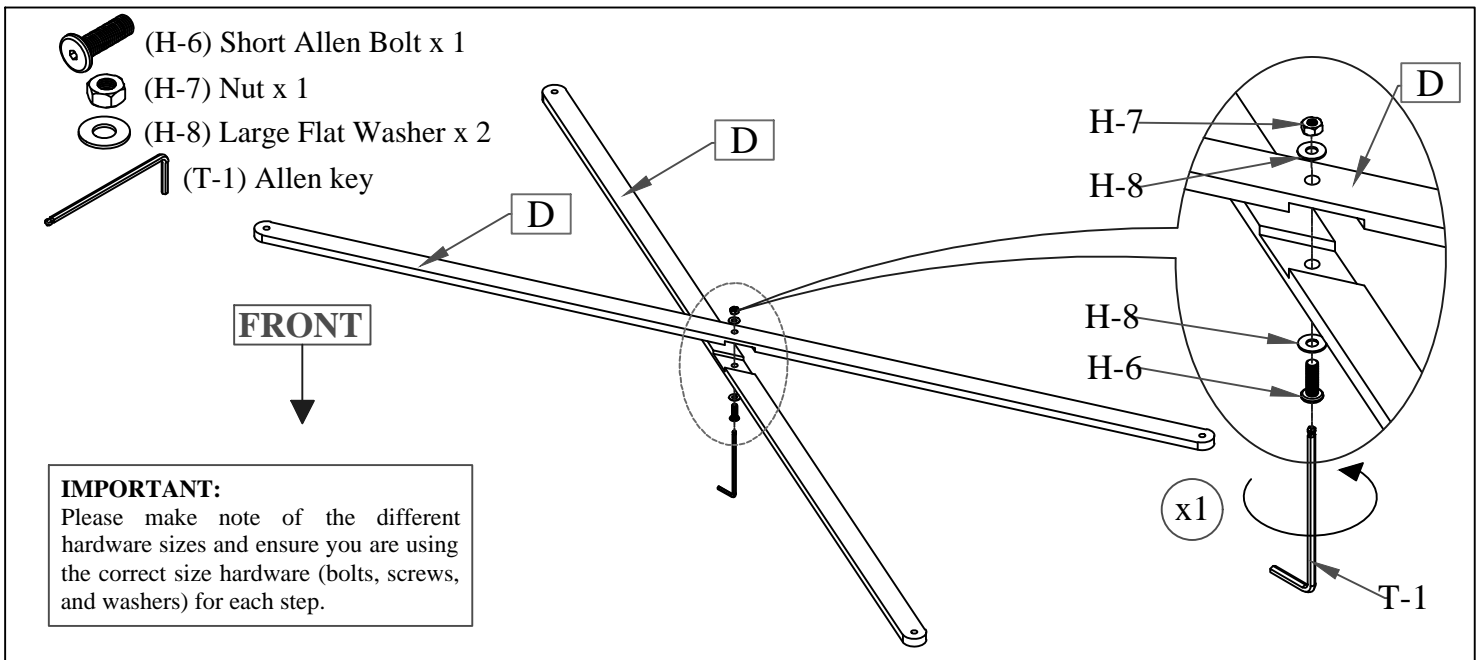

Position both Supports (D) together by nesting the notches in the middle. Secure connection with a Short Allen Bolt (H-6), two Large Flat Washers (H-8) and a Nut (H-7) using the provided Allen Key (T-1), stacking the hardware in the order as shown. Fully tighten but **DO NOT OVER TIGHTEN**.

Step 4

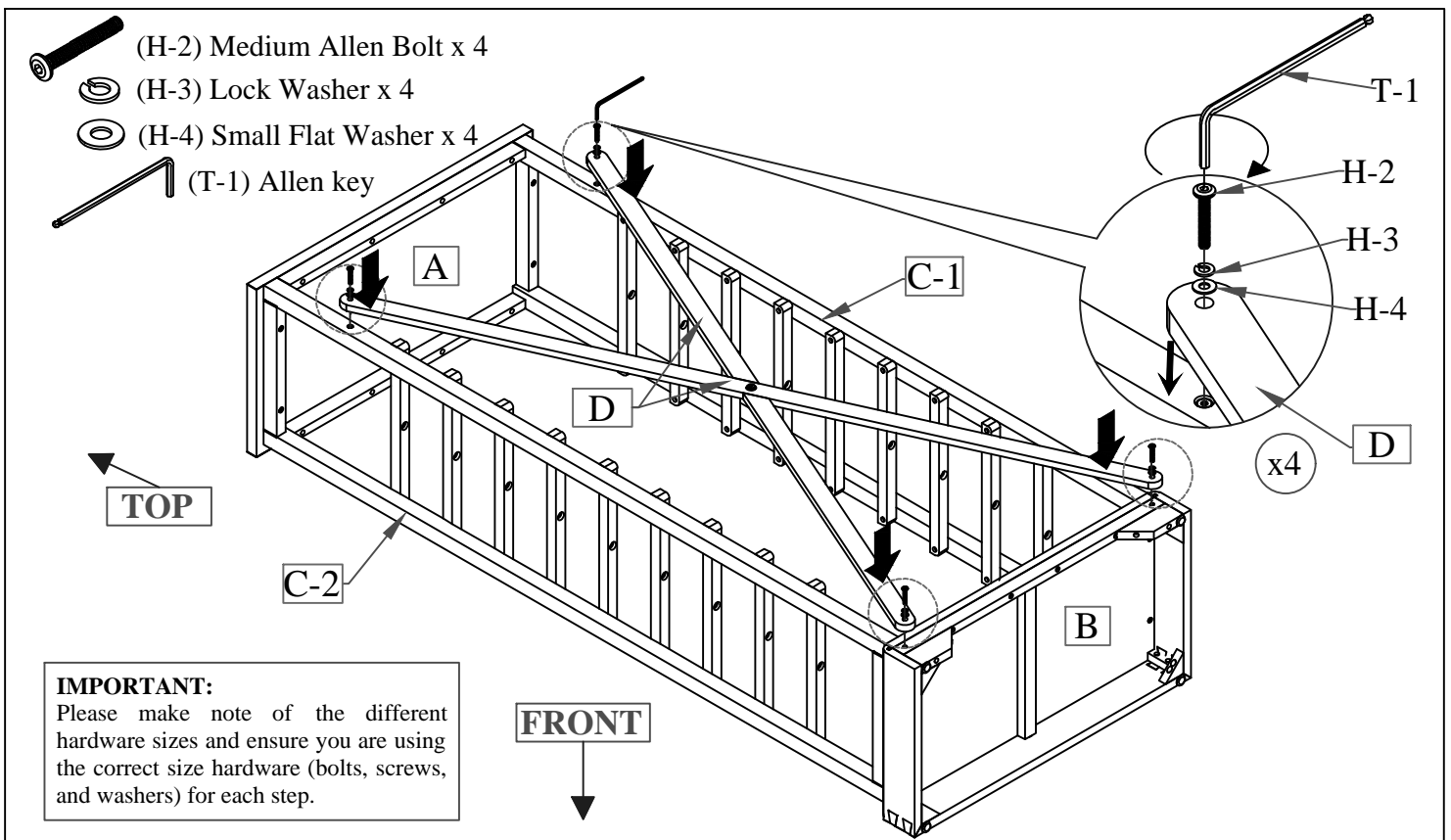

Using a second person to assist you, carefully position the assembled Supports (D) from the previous step onto the assembly. Secure Supports (D) with Left/Right Side Frames (C-1/C-2) with Medium Allen Bolts (H-2), Lock Washers (H-3) and Small Flat Washers (H-4) using the provided Allen Key (T-1), stacking the hardware in the order as shown. Engage all hardware first, then fully tighten. **DO NOT OVER TIGHTEN**.

Step 5.1

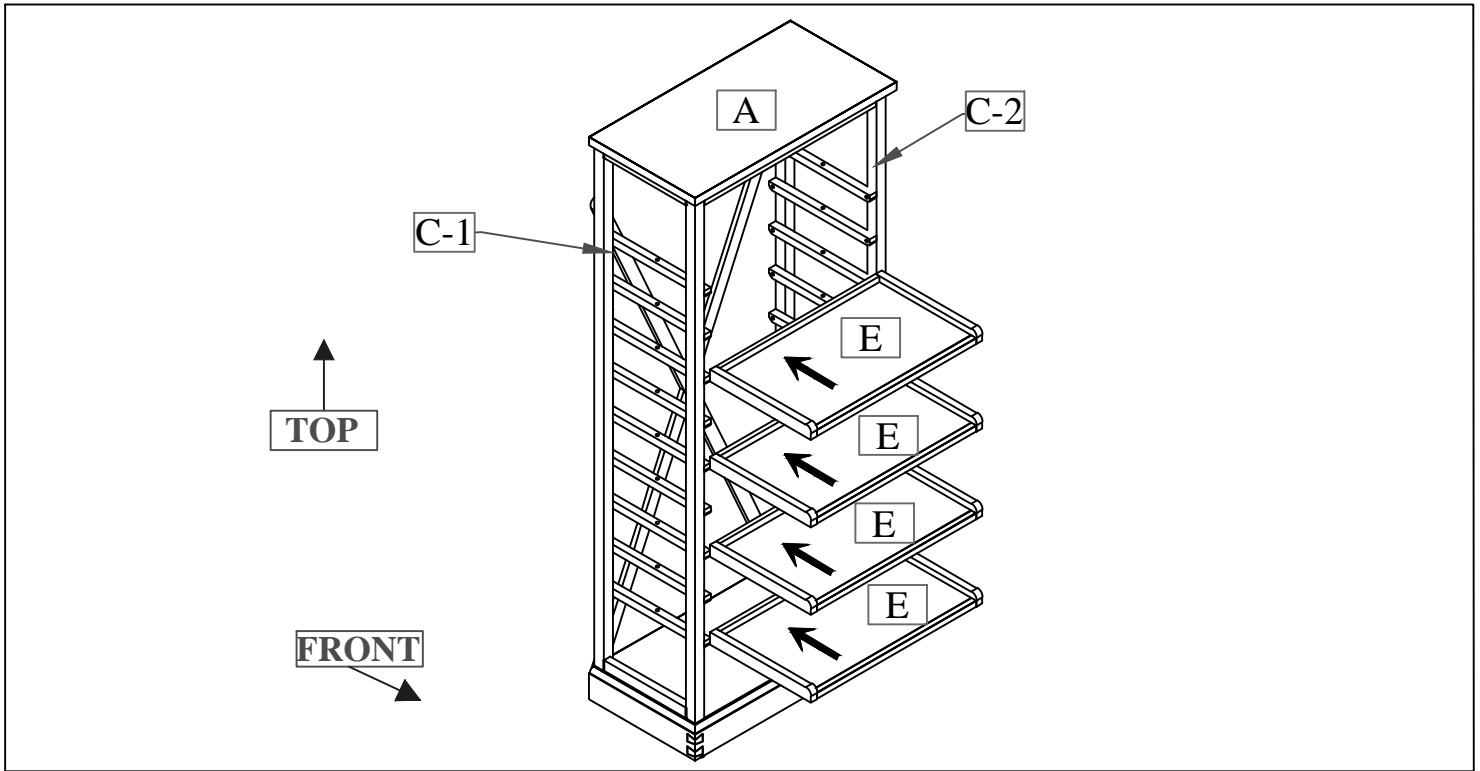

Using a second person to assist you, carefully turn the assembled unit upright. Place Shelf Frames (E) on the support bars of Left/Right Side Frames (C-1/C-2) at your desired positions.

Step 5.2

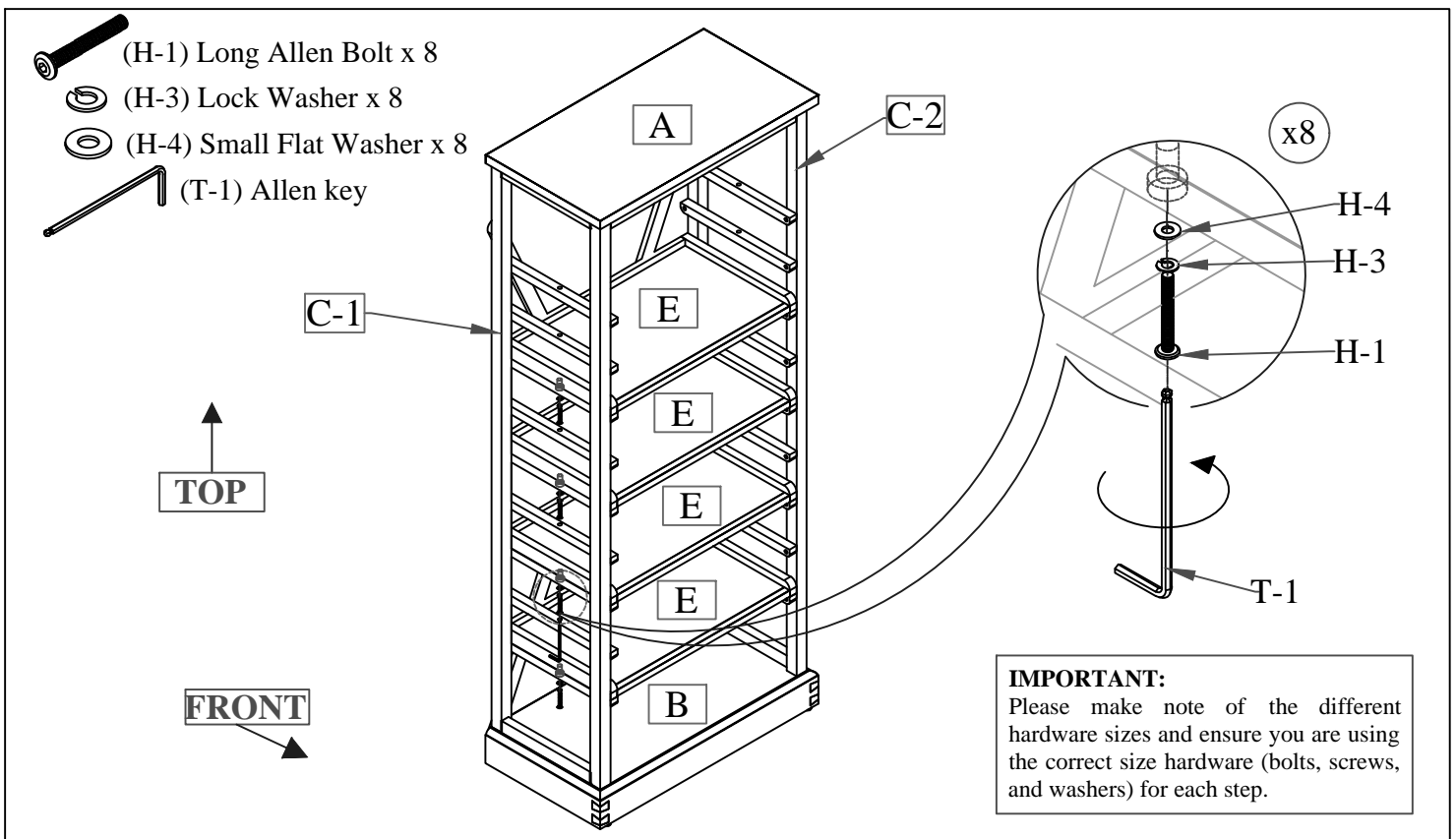

Secure Shelf Frames (E) with Left/Right Side Frames (C-1/C-2) with Long Allen Bolt (H-1), Lock Washer (H-3) and Small Flat Washer (H-4) using the provided Allen Key (T-1), stacking the hardware in the order as shown. Engage all hardware first, then fully tighten. **DO NOT OVER TIGHTEN.**

Step 6

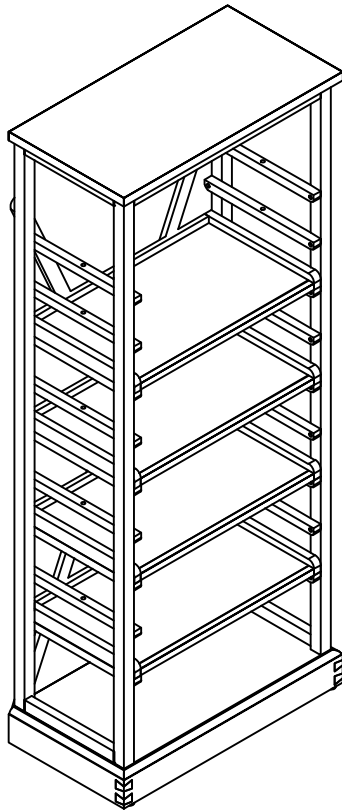

Assembly is now complete and the product is ready for use.

** NOTE: Hardware may loosen over time.

Periodically check that all connections remain tight and adjust as needed.

Anti-Tip Measures

WARNING

Furniture tip overs can result in death or serious injuries. To reduce the likelihood of tip over, this product should be used with the enclosed Anti-Tip Kit. This Anti-Tip Kit is only a deterrent. It is not a substitute for proper adult supervision. Manufacturer and retailer assume no liability for improper installation or excess loads placed on screws, brackets, or straps. When properly installed, this restraint provides protection against unexpected tipping of furniture. This Anti-Tip Kit **MUST** be installed into the wall using proper mounting hardware **OR** into a wall stud using appropriate screws. Position of the Anti-Tip Kit depends on the product and the location of the wall studs. The hardware provided is not a comprehensive solution for all wall types. Be sure to consult a professional or your local hardware store to determine the hardware needed for your specific wall type (plaster, drywall, concrete, etc.).

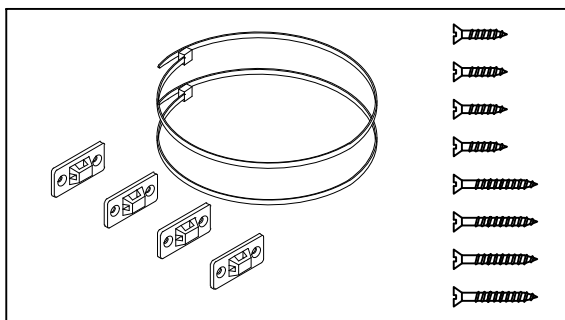

Anti-Tip kit contents

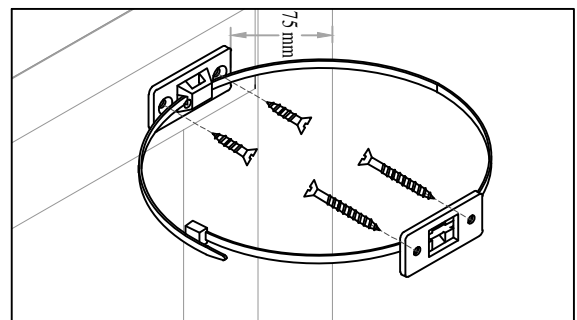

Anti-Tip kit installation

Using a second person to assist you, place the unit in the desired final location against a wall. It is suggested to use a stud finder to find wall studs along the length of the unit and roughly 1 inch below the top. Where possible, mark a drill hole position on the wall where there is a stud and use a Drill or Screwdriver (**NOT INCLUDED**) to attach Wall Brackets to the wall using Long Screws in the location of the wall studs.

In a case where there is no wall stud, hold Brackets on wall and mark the drill hole positions so that they are roughly 1 inch below the top of the piece. Using a Drill (**NOT INCLUDED**) with a drill bit roughly the diameter of the plastic Wall Plugs, drill pilot holes in marked positions. Insert the plastic Wall Plugs into the holes until the tops are roughly flush with the wall. Align the holes and insert the Long Screws through Brackets and into the corresponding holes in the wall using a Phillips Head Screwdriver (**NOT INCLUDED**).

Next, attach remaining 2 Brackets to the back of the piece using Short Screws so they align with Brackets installed on the wall. Loop Straps through Brackets (A) on the furniture piece, then through Brackets on the wall and tighten until snug. Installation is now complete.

IMPORTANT: Check that the Wall Brackets are firmly screwed into the wall and the Cable Ties are snug.

If there is any hesitation, please consult a professional or your local hardware store.

Warnings

WARNING



Children have died from furniture tip over. To reduce the risk of furniture tip over:

- **ALWAYS** install Anti-Tip device provided.
- **NEVER** put a TV on this product.
- **NEVER** allow children to stand, climb or hang on any drawers, doors or shelves.
- **NEVER** open more than one drawer at a time.
- **DO NOT** defeat or remove any drawer interlock system if included with the product; it is an important stability and safety system.
- **Place heaviest items in the lowest drawers.**



Not intended for clothing storage use.



All products sold at World Market are not for commercial use and are intended for residential use only.

Care & Maintenance



DO NOT put hot items directly on furniture surface.



DO NOT clean furniture with harsh cleansers or polish.



DO NOT place furniture in direct sunlight.



DO NOT place furniture near heating or cooling vents.



DO NOT write on furniture without a padded barrier to protect the surface.



DO NOT place furniture outside. For **INDOOR USE ONLY**.



Dust and pick up spills using a clean, non-colored, lint-free dry cloth.

WORLD MARKET LIMITED ONE-YEAR WARRANTY – Indoor Furniture

For your customer satisfaction, this product carries a LIMITED ONE-YEAR WARRANTY from the date of delivery. This limited warranty only applies to World Market brand furniture, and not to other furniture brands sold on World Market's website.

Where applicable, the limited warranty provides coverage for:

1. **Manufacturing, Material and Workmanship Defects:** Includes defects related to core frame/structure substrates (wood and metal); cracking, splitting, or complete breakage of hardwood, plywood or medium density fiberboard (MDF); cracking, splitting or lifting of wood veneer or laminated top surfaces caused by process failure; broken welds or improperly coated metal frame components (powder coating or painted); fabric or leather material defects including tears, misprints, fraying, crease marks, skip stitches or open seams; support webbing material and sinuous spring defects or damage, including method of attachment to frame; and other component failures that are a direct result of manufacturing or workmanship defects.
2. **Cushions & Cushions with Enclosed Steel Pocket Coils:** Failed or ruptured steel pocket coils enclosed inside of seat cushions, or loss of resiliency from a material breakdown of foam or fiber filling, which should not be confused with softening or settling during normal use.
3. **Leather:** Splitting or cracking of leather material. NOTE: The warranty does NOT cover natural hide markings, variations in the leather color or grain due to the authentic natural properties of processed cowhide leather.
4. **Bonded Leather or Bi-cast Leather:** Separation of the polyurethane coating, peeling or cracking of the inner layer or at the bonded seam edges (bi-cast straps).
5. **Furniture Components (Hardware & Mechanisms):** Includes defects to pre-installed components or hardware provided to the customer for assembly such as office chair hydraulic lifts, lift mechanisms, metal bases and casters, swivel plate mechanisms; for drawers, metal glides, handles/knobs; for doors, hinges, magnetic latches; and other components such as bent or stripped threaded leg posts and adjustable levelers. For missing, damaged, corroded, or misplaced hardware components such as bolts or washers, please contact Customer Service at: 877-967-5362.

This LIMITED ONE-YEAR WARRANTY does NOT cover:

1. Damage due to mishandling during transportation from store or transportation without original protective packaging.
2. Abuse, negligence (product misuse) or wear and tear that may result in or from:
 - a. **Wood & Veneer:** Mishandling, exposure to moisture, peeling or discoloration caused by exposure to moisture or excessive sunlight, heat; splintered, dented or nicked panels, legs or component edges or paint/finish blemishes; or treatment with corrosive chemicals (dyes, inks, paints or harsh cleaning products).
 - b. **Fabric & Leather (Including Bonded or Bi-Cast Leathers):** cuts, punctures, tears, burns, pet damage, or treatment with corrosive chemicals (dyes, inks, paints or harsh cleaning products), exposure to direct sunlight, fire, high heat, water, or any bright light source (natural or artificial) that may cause splitting, peeling or flaking with time.
 - c. **Foam (Cushions):** Flattening, relaxing or settling/softening of foam components that comes with normal use.
 - d. **Hardware Components:** improper installation or misuse/substitution of hardware components not defined in the Assembly Instructions for the product (if applicable)
3. Damage due to environmental exposure to direct sunlight, fire, high heat, water or extreme humidity, any bright light source (natural or artificial), or any environment that the product is not intended for.
4. This warranty is applicable for indoor furniture products purchased for residential use only.

For additional information on returns, please visit: <https://www.worldmarket.com/category/customer-service/returns.do>

All products sold at World Market are NOT FOR COMMERCIAL USE and are intended for residential use only. Products purchased for commercial use will VOID all warranty provisions as listed above.

Any claims under this LIMITED ONE-YEAR WARRANTY are valid and applicable only as to the original purchaser and must be accompanied by proof of purchase. Warranty claims should be submitted to a World Market store or through World Market Customer Service Call Center, Toll Free at 877-967-5362.

For valid warranty claims, World Market will repair or replace the product, or offer a full or partial credit, in the sole discretion of World Market. This LIMITED ONE-YEAR WARRANTY gives you specific legal rights and you may also have other rights which vary from state to state.